

This document and the information disclosed herein are proprietary information of Airglas, Inc. Neither this document nor the information contained herein shall be transmitted, reproduced, copied, or disclosed in any form or by any means without the written authorization of Airglas, Inc.

The information disclosed herein includes trade secrets and confidential business and/or financial information and falls within exemption (b) (4) of 5 USC 552 (FOIA) and the prohibitions of 18 USC 1905.

This drawing includes information proprietary to Airglas, Inc. and is submitted for evaluation only and shall not be used to manufacture or reproduce without the permission of Airglas, Inc.

REVISIONS			
REV	DESCRIPTION	DATE	APPROVED BY
A	ADDED NOTE 1. CORRECTED QTY OF ITEM 14.	2/26/2015	CDB
B	ADDED NOTES 2-4. REVISED FUSELAGE ATTACH POINTS. REVISED BOM.	12/14/2015	CDB
C	ADDED GENERAL TORQUE SPECIFICATIONS	4/4/2016	CDB
D	ADDED BOLT CALL OUT FOR NOTE 3. ADDED 7/8 DIAMETER CLAMP OPTION FOR ITEM 18A DETAIL A.	6/6/2016	CDB
E	ADDED ITEM 24A. ADJUSTED BOM QTS FOR ITEM 24. REVISED NOTE ON ITEM 18.	7/25/2016	CDB
F	ADDED ITEMS 31 THRU 34 ON BOM. REVISED NOTE 1. ADDED "D" RING DETAIL.	11/18/2016	CDB
G	ADDED OPTIONAL LENGTHS FOR ITEM 21. ADDED PROCEDURE FOR FIELD MODIFICATION OF ITEM 21.	1/9/2017	CDB

NOTES

- ITEMS 2 THRU 15 AND 31 THRU 34 IN LIST OF MATERIALS ARE INSTALLED ON THE LC18-ACA AT MANUFACTURE. THESE ITEMS ARE INCLUDED IN THE LIST OF MATERIALS FOR THE CONVENIENCE OF THE CUSTOMER.
- REMOVE INTERIOR FABRIC TO GAIN ACCESS TO AFT SIDE OF FABRIC. SLIT FABRIC ALONG LONGERON TO ADMIT CLAMPS. TRIM METAL BELLY IF INSTALLED, TRIM PLYWOOD FLOOR BOARD IF NEEDED TO CLEAR CLAMP.
- INSTALLATION ON SCOUT AIRCRAFT SERIAL NO.: 1-74, 37-74, 129-75, AND 135-75 & UP. INSTALLATION ON ALL 7 AND 8 SERIES AIRCRAFT WITH WELDED GUSSETS.
- INSTALLATION ON SCOUT AIRCRAFT SERIAL NO.: 2-74 THRU 36-74, 38-74 THRU 119-74, 120-75 THRU 128-75, 130-75 THRU 134-75. INSTALLATION ON ALL 7 AND 8 SERIES AIRCRAFT W/O WELDED GUSSETS.
- 8GCBC AND 8KCAB USE LTC18-8-7/8 CLAMP ON DIAGONAL.

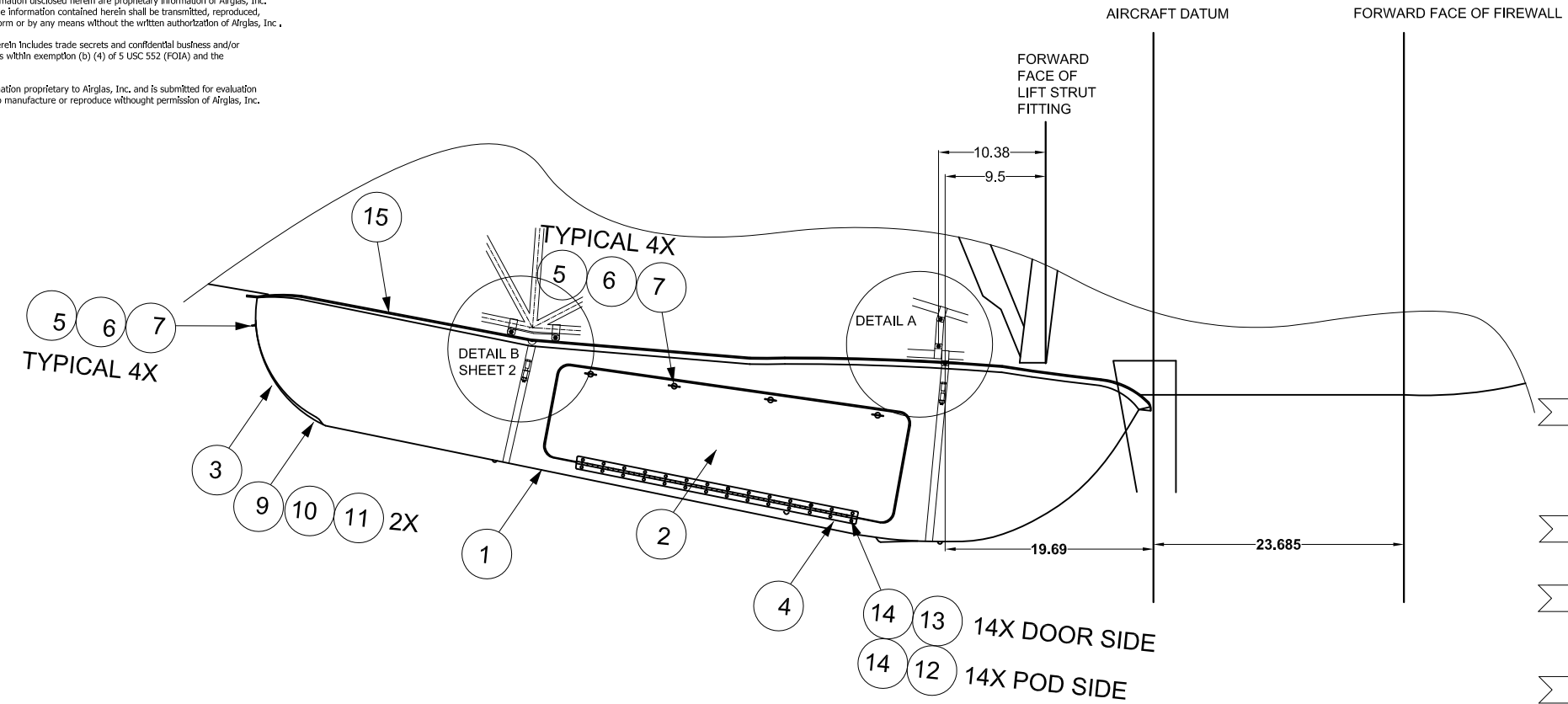

**FASTENER TORQUE VALUES
UNLESS SPECIFIED OTHERWISE:
TORQUE ALL FASTENERS IAW AC 43.13-1B
TABLE 7-1**

← INSIDE OF POD

POD LAMINATE

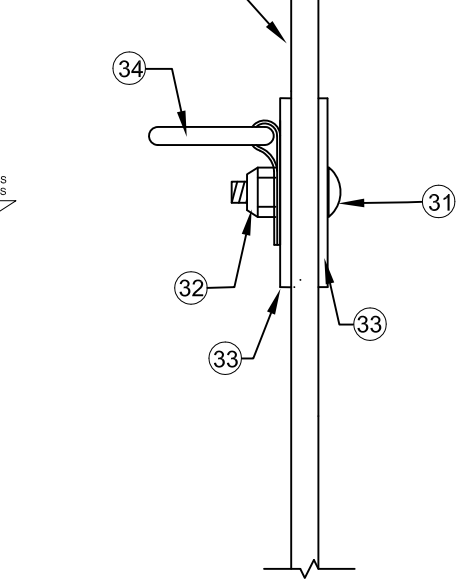

"D" RING INSTALLATIONS

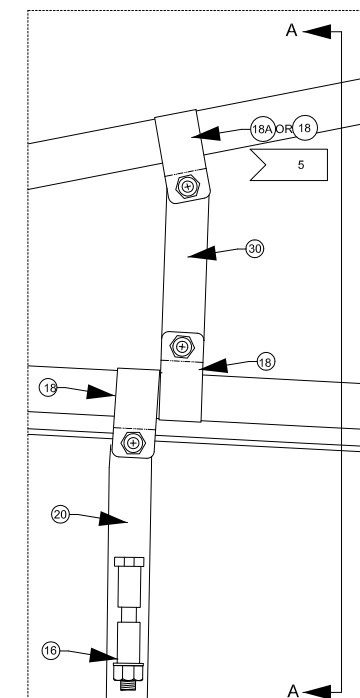

**DETAIL A
LH SIDE**

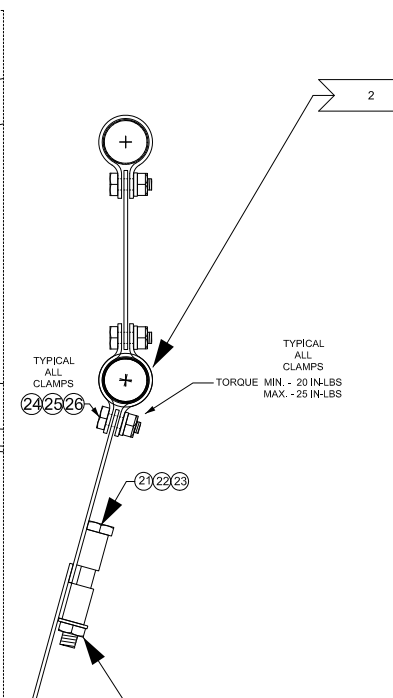

SECTION A-A

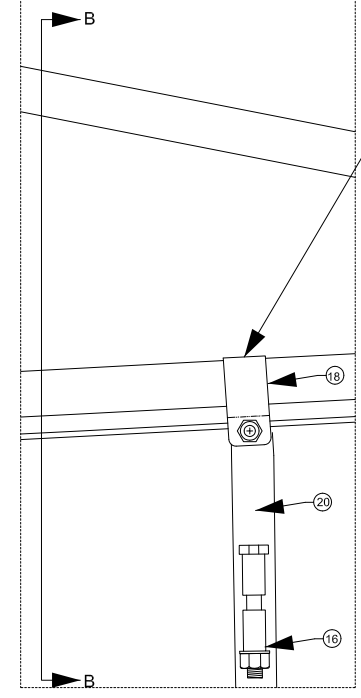

**DETAIL A
RH SIDE**

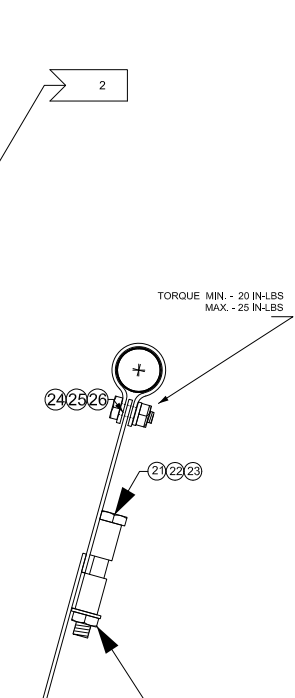

SECTION B-B

NO.	QTY	CODE-IDENT-NO	PART NO.	DESCRIPTION	NOTES
34	8	17564	SSDRC-3/4	"D" RING	
33	16		AN970-3	LARGE AREA WASHER	
32	8		MS21044N3	NUT	
31	8		AN525-10R(X)	SCREW	AN525-10R9 TOP "D" RINGS, AN525-10R10 BOTTOM LEFT "D" RINGS, AN525-10R12 BOTTOM RIGHT "D" RINGS
30	1	17564	LTC18-8-2	STRAP ASSY	
29	2		NAS1149F0463P	WASHER	USED WITH WELDED TAB PER NOTE 3
28	2		MS21044N4	NUT	USED WITH WELDED TAB PER NOTE 3
27	2		AN4-5A	BOLT	USED WITH WELDED TAB PER NOTE 3
26	12		MS21044N3	NUT	
25	12		AN960-10	WASHER	
24A	6		AN3-6A	BOLT	USED WITHOUT WELDED TAB PER NOTE 4
24	4		AN3-4A	BOLT	
23	4		MS21042-4	NUT	
22	4		AN960-416	WASHER	
21	4	17564	MS90727-16MOD	BOLT MODIFIED	UP TO MS90727-19 OR AN4-24A THRU AN4-32A MAY BE USED. SEE FIELD MODIFICATION ON SHEET 2.
20B	2	17564	LTC18-8-3	STRAP ASSY	USED WITHOUT WELDED TAB PER NOTE 4
20A	2	17564	LTC18-5-ACA	STRAP ASSY	USED WITH WELDED TAB PER NOTE 3
20	4	17564	LTC18-5	STRAP ASSY	USED WITHOUT WELDED TAB PER NOTE 4
19	4	17564	LTC18-8	CLAMP	USED WITHOUT WELDED TAB PER NOTE 4
18A	1	17564	LTC18-8	CLAMP	SEE NOTE 5
18	3	17564	LTC18-8-7/8	CLAMP	SEE NOTE 5 (4 REQUIRED FOR 8KCAB AND 8GCBC)
17	1	17564	LC18-ACA-4	REARSTRAP ASSY	
16	1	17564	LC18-ACA-3	FRONT STRAP ASSY	
15	A/R		7757801222	FOAM SEAL	FROST KING R534 3/4" X 5/16" X 120"
14	28		NAS1149FN616P	WASHER	
13	14		MS20426A-4-X	RIVET	
12	14		MS20470A-4-X	RIVET	
11	8		MS20470A-4-X	RIVET	
10	2	17564	LTC18-2B-2	STRAP ASSY	
9	4	17564	LTC18-2B-1	DOUBLER	
8			RESERVED	RESERVED	
7	8		S5A-250	SPRING	
6	8		GA5-375	GROMMET	
5	8		AJW5-45	STUD,DZUS	
4	1		MS20257-4-2700	HINGE	ALT: MS20257P4-2700 LENGTH 27"
3	1	17564	LC18-ACA-2B	AFT DOOR	
2	1	17564	LC18-ACA-2	SIDE DOOR	
1	1	17564	LC18-ACA-1	CARGO POD	
X		17564	LC18-ACA	CARGO POD KIT	

UNLESS OTHERWISE SPECIFIED DIMENSIONS ARE IN INCHES		CONTRACT NO. / SPEC. CONTROL NO.		Airglas, Inc. Anchorage, Alaska	
DECIMALS	.X ± .5 .XX ± .5 .XXX ± .5	ANGLES	" ± 10"	LC18-ACA CARGO POD INSTALLATION	
HEAT TREAT		Checked by:		Scale: DO NOT SCALE	
MATERIAL	GOV. SPEC.	Checked by:		REV	
STEEL	MIL - H - 6875	Checked by:		B 17564	
ALUM.	MIL - H - 8088	Checked by:		LC18-ACA	
MAG. CAST	MIL - H - 6857	Checked by:		G	
NEXT ASSY.	USED ON	Date: 5-14-13		Sheet 1 OF 2	

This document and the information disclosed herein are proprietary information of Airglas, Inc. Neither this document nor the information contained herein shall be transmitted, reproduced, copied, or disclosed in any form or by any means without the written authorization of Airglas, Inc.

The information disclosed herein includes trade secrets and confidential business and/or financial information and falls within exemption (b) (4) of 5 USC 552 (FOIA) and the prohibitions of 18 USC 1905.

This drawing includes information proprietary to Airglas, Inc. and is submitted for evaluation only and shall not be used to manufacture or reproduce without permission of Airglas, Inc.

NOTES

1. ITEMS 2 THRU 15 AND 31 THRU 34 IN LIST OF MATERIALS ARE INSTALLED ON THE LC18-ACA AT MANUFACTURE. THESE ITEMS ARE INCLUDED IN THE LIST OF MATERIALS FOR THE CONVENIENCE OF THE CUSTOMER.
2. REMOVE INTERIOR FABRIC TO GAIN ACCESS TO AFT SIDE OF FABRIC. SLIT FABRIC ALONG LONGERON TO ADMIT CLAMPS. TRIM METAL BELLY IF INSTALLED, TRIM PLYWOOD FLOOR BOARD IF NEEDED TO CLEAR CLAMP.
3. INSTALLATION ON SCOUT AIRCRAFT SERIAL NO.: 1-74, 37-74, 129-75, AND 135-75 & UP. INSTALLATION ON ALL 7 AND 8 SERIES AIRCRAFT WITH WELDED GUSSETS.
4. INSTALLATION ON SCOUT AIRCRAFT SERIAL NO.: 2-74 THRU 36-74, 38-74 THRU 119-74, 120-75 THRU 128-75, 130-75 THRU 134-75. INSTALLATION ON ALL 7 AND 8 SERIES AIRCRAFT W/O WELDED GUSSETS.
5. 8GCBC AND 8KCAB USE LTC18-8-7/8 CLAMP ON DIAGONAL.

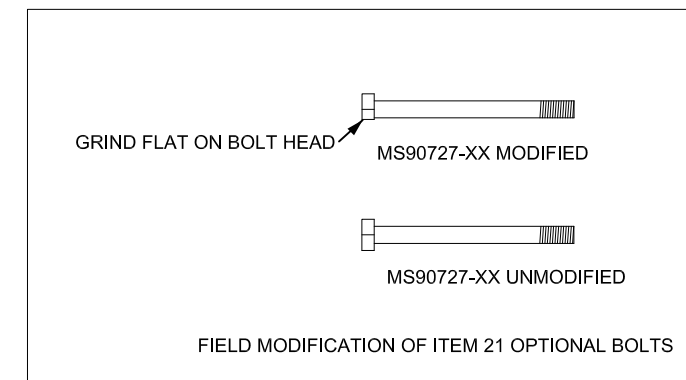

**FASTENER TORQUE VALUES
UNLESS SPECIFIED OTHERWISE:
TORQUE ALL FASTENERS IAW AC 43.13-1B
TABLE 7-1**

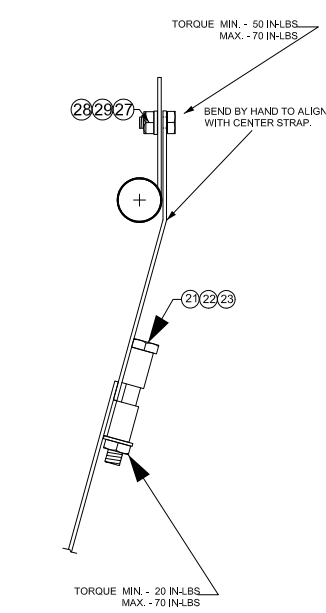
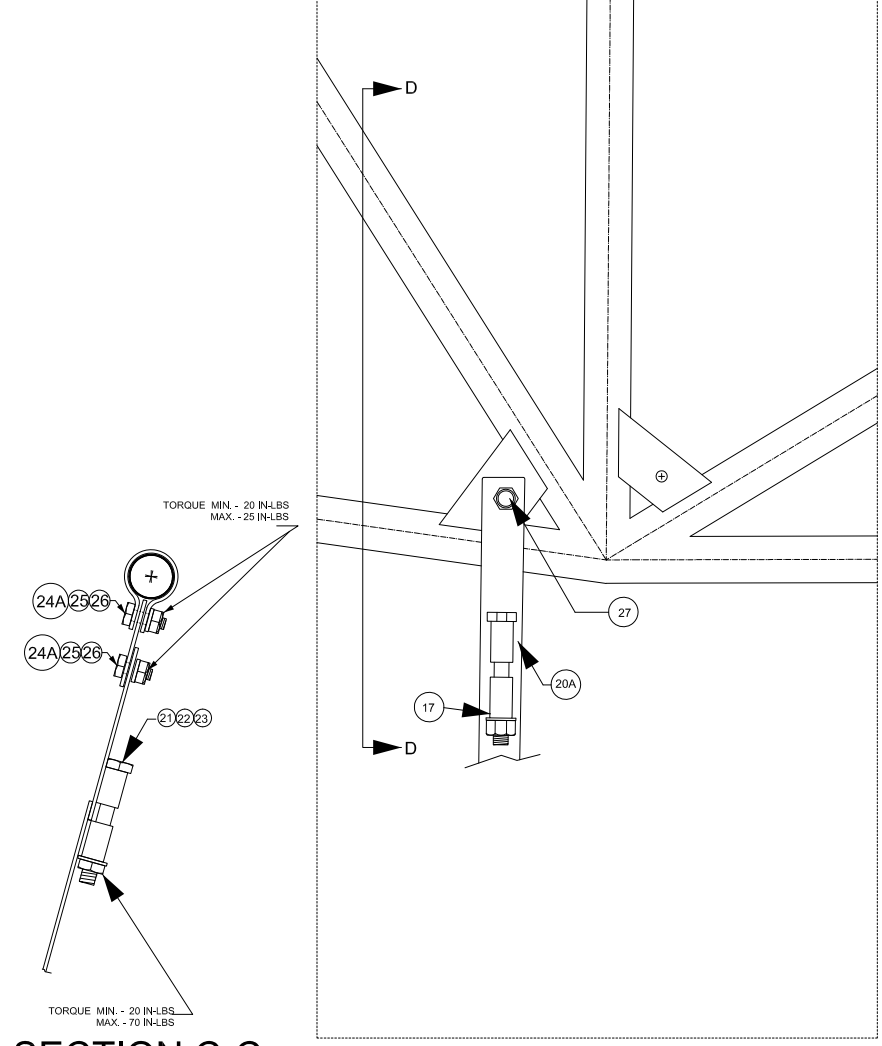
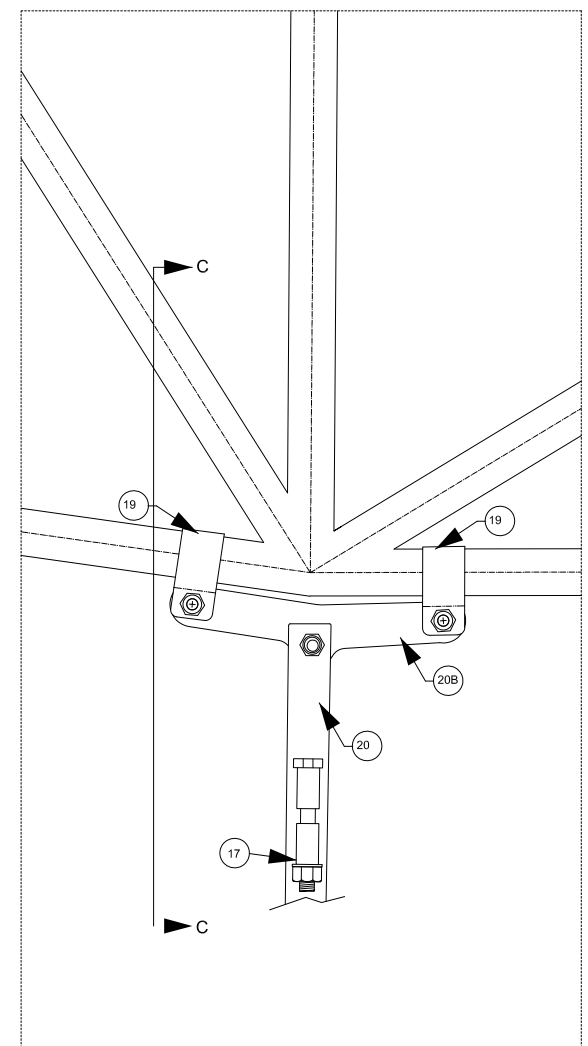

SECTION D-D

2 DETAIL B RIGHT HAND
4 DEPICTED LH OPOSITE

SECTION C-C

2 DETAIL B RIGHT HAND
3 DEPICTED LH OPOSITE

UNLESS OTHERWISE SPECIFIED DIMENSIONS ARE IN INCHES		CONTRACT NO.	Airglas, Inc. Anchorage, Alaska	
DECIMALS	X ± .5 XX ± .5 XXX ± .5	SPEC. CONTROL NO.	LC18-ACA CARGO POD INSTALLATION	
ANGLES	X° ± 10°	Approved by:	Rev Code Ident. No.	REV
HEAT TREAT	GOV. SPEC.	Checked by:	B 17564	LC18-ACA
MATERIAL	MIL - H - 6875	Drawn by: CDB	Scale: DO NOT SCALE	G
STEEL	MIL - H - 6088	Date: 5-14-13	Sheet	2 OF 2
ALUM.	MIL - H - 6857			
MAG. CAST				
NEXT ASSY.	USED ON			
APPLICATION				