

REVISIONS			
REV	DESCRIPTION	DATE	APPROVED BY
A	CORRECTED ITEM 10 LENGTH	7/15/2014	CDB
B	REVISED DRAWING TITLE	8/14/2014	CDB

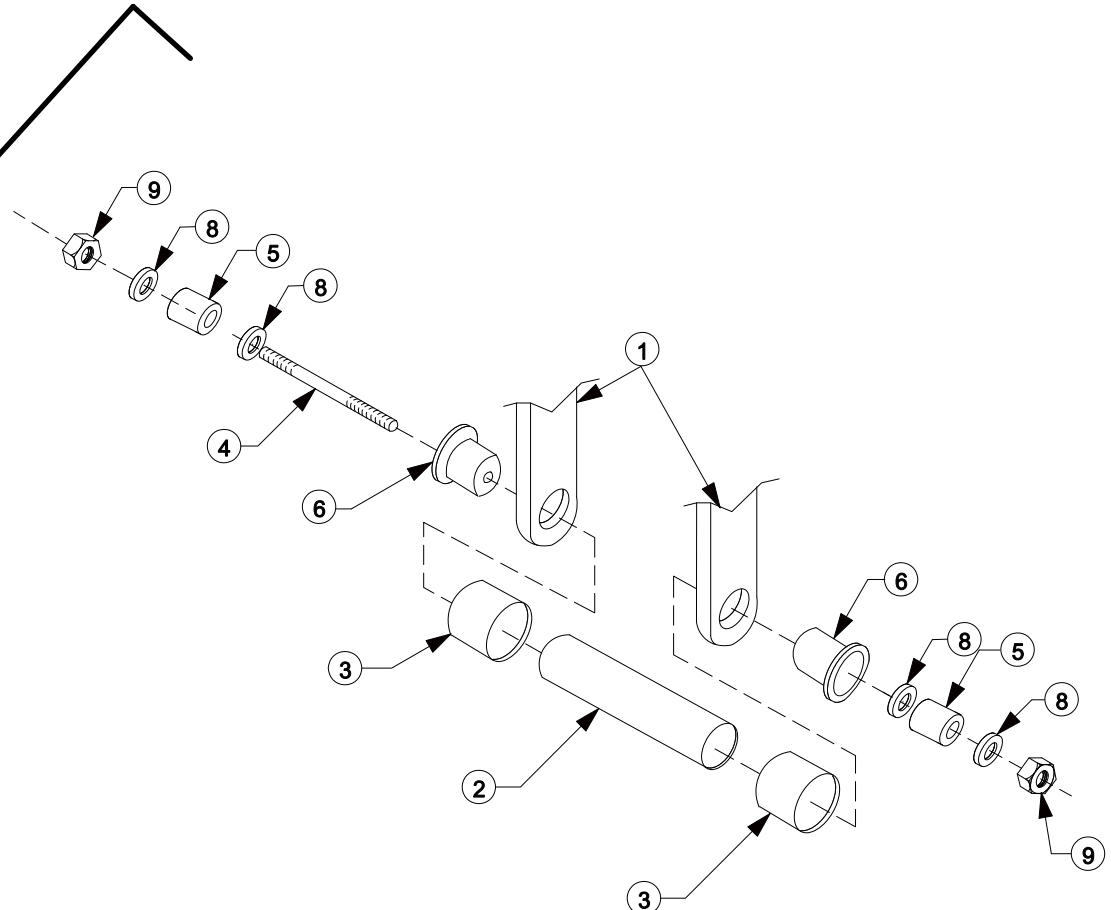
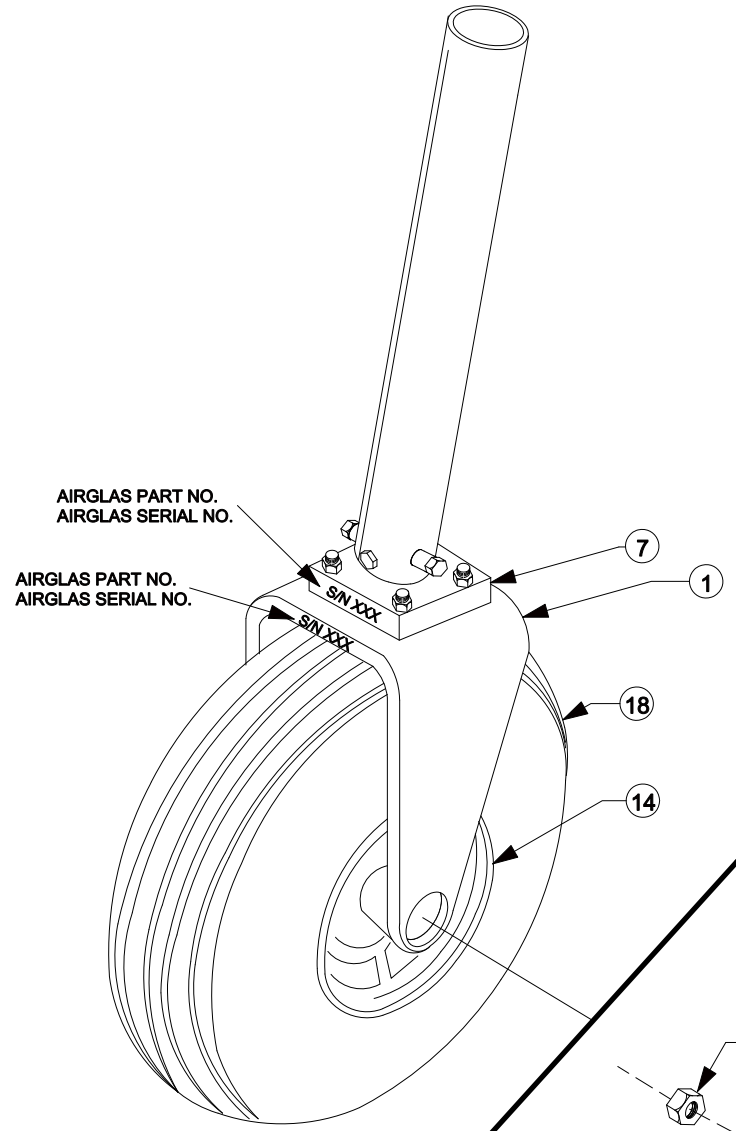
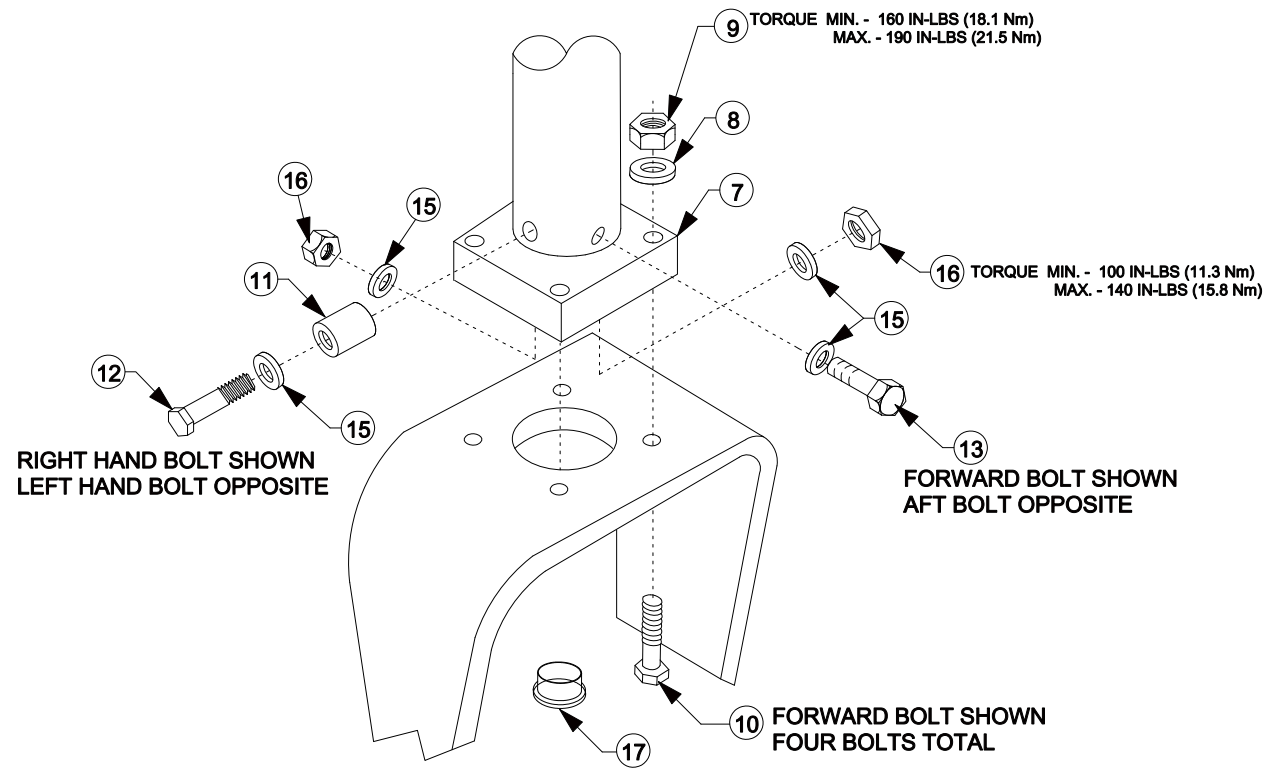

ITEM NO.	QTY.	CODE-IDENT-NO	PART NO.	DESCRIPTION	NOTES	MATERIAL	MATERIAL-SPEC
18	1		8.50 X 6 SIX PLY	TIRE AND TUBE	REF: NOT SUPPLIED		
17	1		GA8-322021-137	NOSE WHEEL FORK PLUG	REF: NOT SUPPLIED		
16	4		MS21042-5	NUT	REF: NOT SUPPLIED		
15	A/R		AN960-516L	WASHER	REF: NOT SUPPLIED		
14	1		40-76A	WHEEL (CLEVELAND)	REF: NOT SUPPLIED		
13	2		AN5-7A	BOLT	REF: NOT SUPPLIED		
12	2		AN5-13A	BOLT	REF: NOT SUPPLIED		
11	2		GA8-322021-093	STEERING LUG	REF: NOT SUPPLIED		
10	4		AN6-13A	BOLT			
9	6		AN365-624C	NUT			
8	8		AN960-616	WASHER	NAS1149F0663P ALTERNATE		
7	1	17564	PA32-GA8L-7	BLOCK			
6	2	17564	PA32-206L-6	BUCKET			
5	2	17564	PA32-206L-5	SPACER			
4	1	17564	PA32-206L-4	AXLE ROD			
3	2	17564	PA32-206L-3	BEARING SPACER			
2	1	17564	PA32-206L-2	AXLE TUBE			
1	1	17564	PA32-206LA-1	NOSE FORK			
x	1	17564	PA32-206LA-GA8	NOSE FORK KIT			

BILL OF MATERIALS			
UNLESS OTHERWISE SPECIFIED DIMENSIONS ARE IN INCHES		CONTRACT NO.	
		SPEC. CONTROL NO.	
HEAT TREAT		Approved by : JDH	
MATERIAL	GOV. SPEC.	Checked by : JDH	
STEEL	MIL - H - 6875	Drawn by : CDB	
ALUM.	MIL - H - 6088	Date : August 14, 2013	
MAG. CAST	MIL - H - 6857		
NEXT ASSY.	USED ON		
APPLICATION			

Airglas, Inc.
Anchorage, Alaska

Installation Drawing
for Airglas, Inc.
PA32-206LA-GA8 Nose Fork Kit

Size	Code Ident.No.	REV
B	17564	B

Scale: DO NOT SCALE Sheet 1 of 1

8 7 6 5 4 3 2 1

8 7 6 5 4 3 2 1