

REV	ECN	DESCRIPTION	APP'D BY	DATE
A	1100-12	PART MARKING	WKL	7-Nov-03
B	1100-54	CHANGED NOTES	WKL	8-Jan-04
C	1100-77	New Length, Eyebolt & Drawing Name	WKL	11-Oct-05

NOTES: UNLESS OTHERWISE SPECIFIED

1. REMOVED ALL BURRS & SHARP EDGES
2. USE A RUBBER STAMP WITH BLACK INDELIBLE INK TO MARK THE PART NUMBER (AFTER PAINTING)
3. TOTAL MAXIMUM WEIGHT 6.0 LBS

TORQUE ALL JAM NUTS 95-110 INCH POUNDS

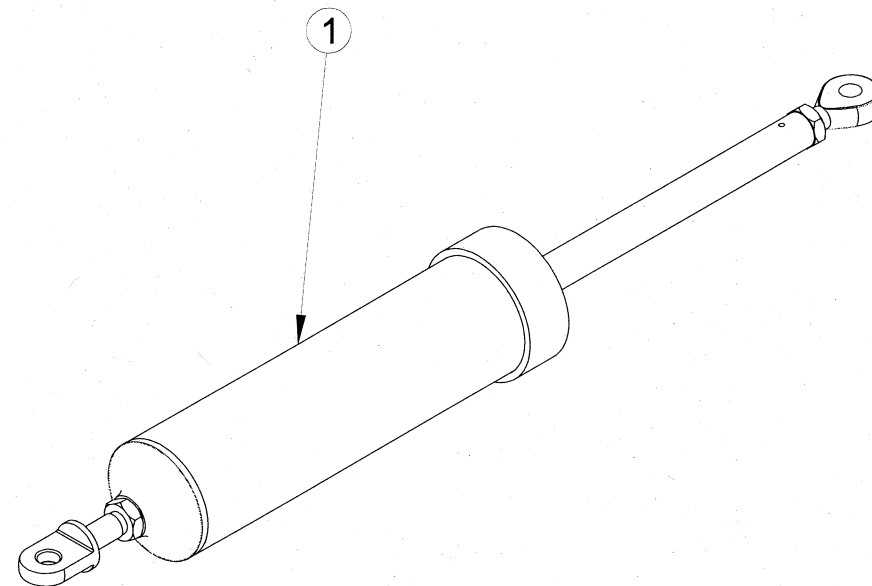
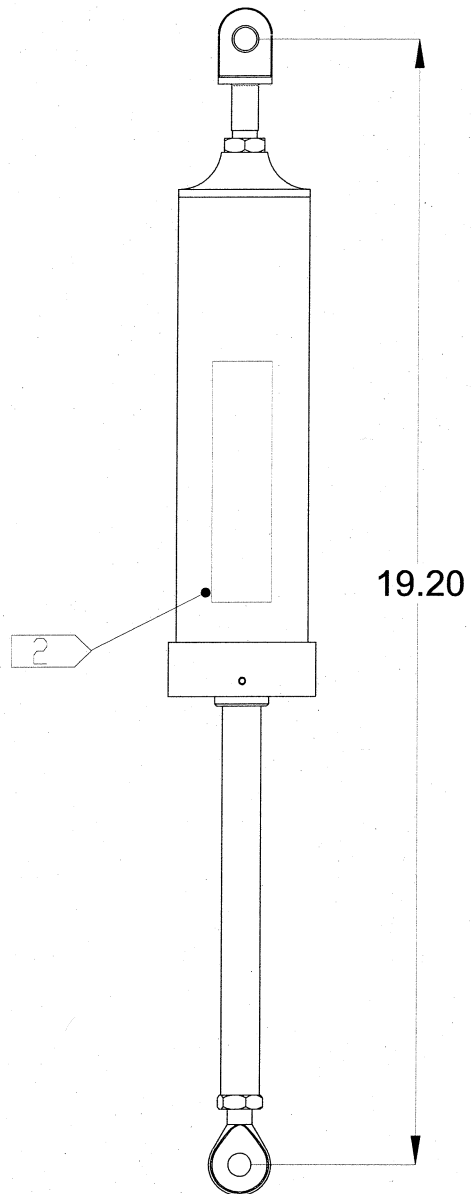

NO.	QTY	CODE IDENT NO.	PART NUMBER	DESCRIPTION	STOCK SIZE	MATERIAL	MATERIAL SPEC.	WEIGHT-LBS	FINISH
1	1	17564	L20500A-15	SPRING CYLINDER, TAIL SKI					

UNLESS OTHERWISE SPECIFIED
DIMENSIONS ARE IN INCHES
TOLERANCES EXCEPT AS NOTED
DECIMALS X ± .1 ANGLES X ± 5°
XX ± .02
XXX ± .005

THIS DRAWING OR DOCUMENT
INCLUDES INFORMATION
PROPRIETARY TO AIRGLAS Inc.
AND IS SUBMITTED FOR
EVALUATION ONLY AND SHALL
NOT BE USED TO MANUFACTURE
OR REPRODUCE WITHOUT
PERMISSION OF AIRGLAS Inc.

AIRGLAS, INC.
Anchorage, Alaska

SPRING CYLINDER, TAIL SKI

Approved by : WKL

Checked by : GL

Drawn by : PCSI

Date : SEPTEMBER 22, 2003

Size
B

Code Ident.No.
17564

L20500A-15A

REV
C

Scale 1:3

Sheet 1 OF 2

L20500A-3 AH-64D

NEXT ASSY USED ON

APPLICATION