

MAIN SKI – AXLE POSITIONING AND ASSEMBLY

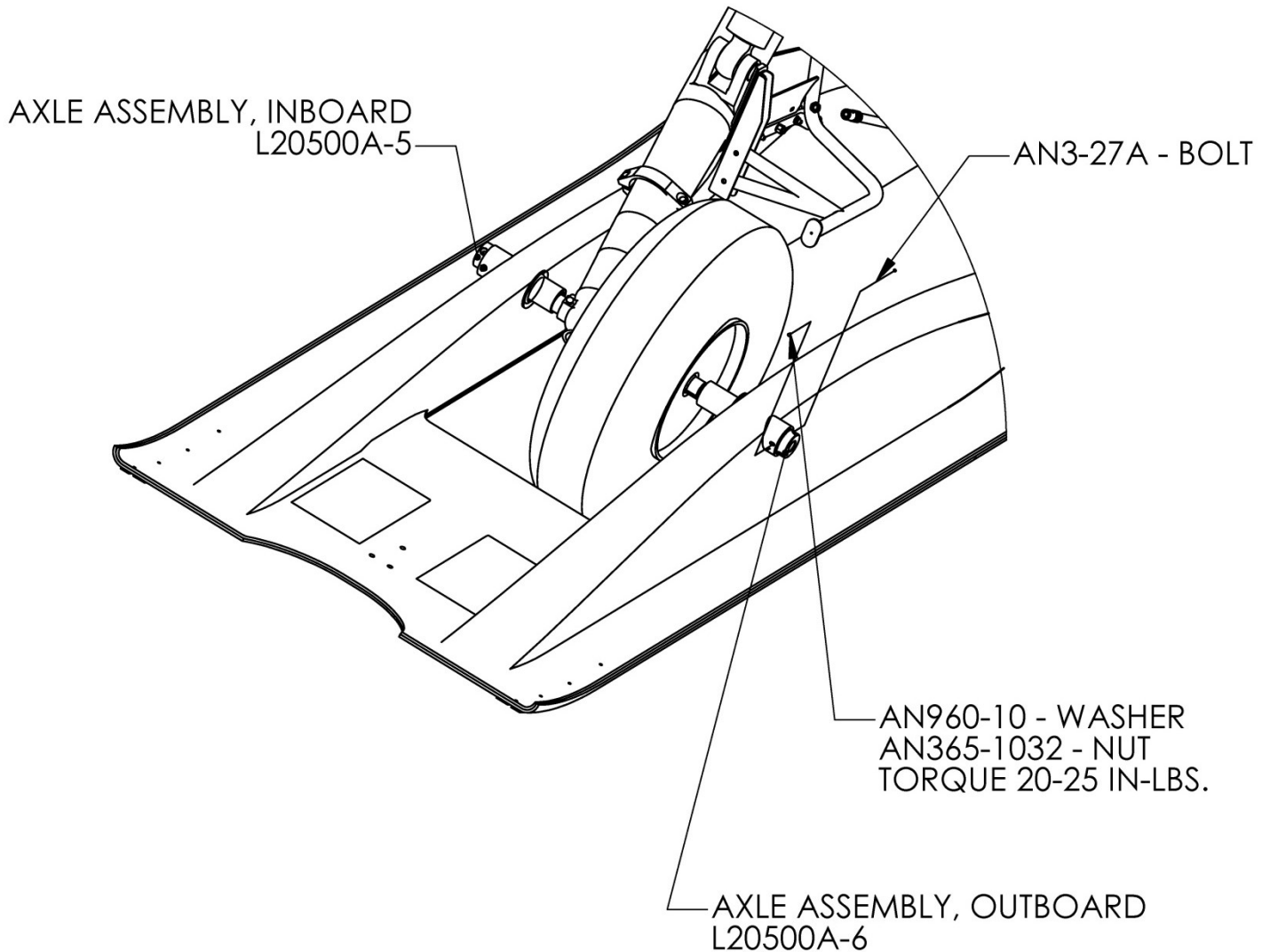

Figure 5.2

MAIN SKI – SPRING CYLINDER POSITIONING AND ASSEMBLY

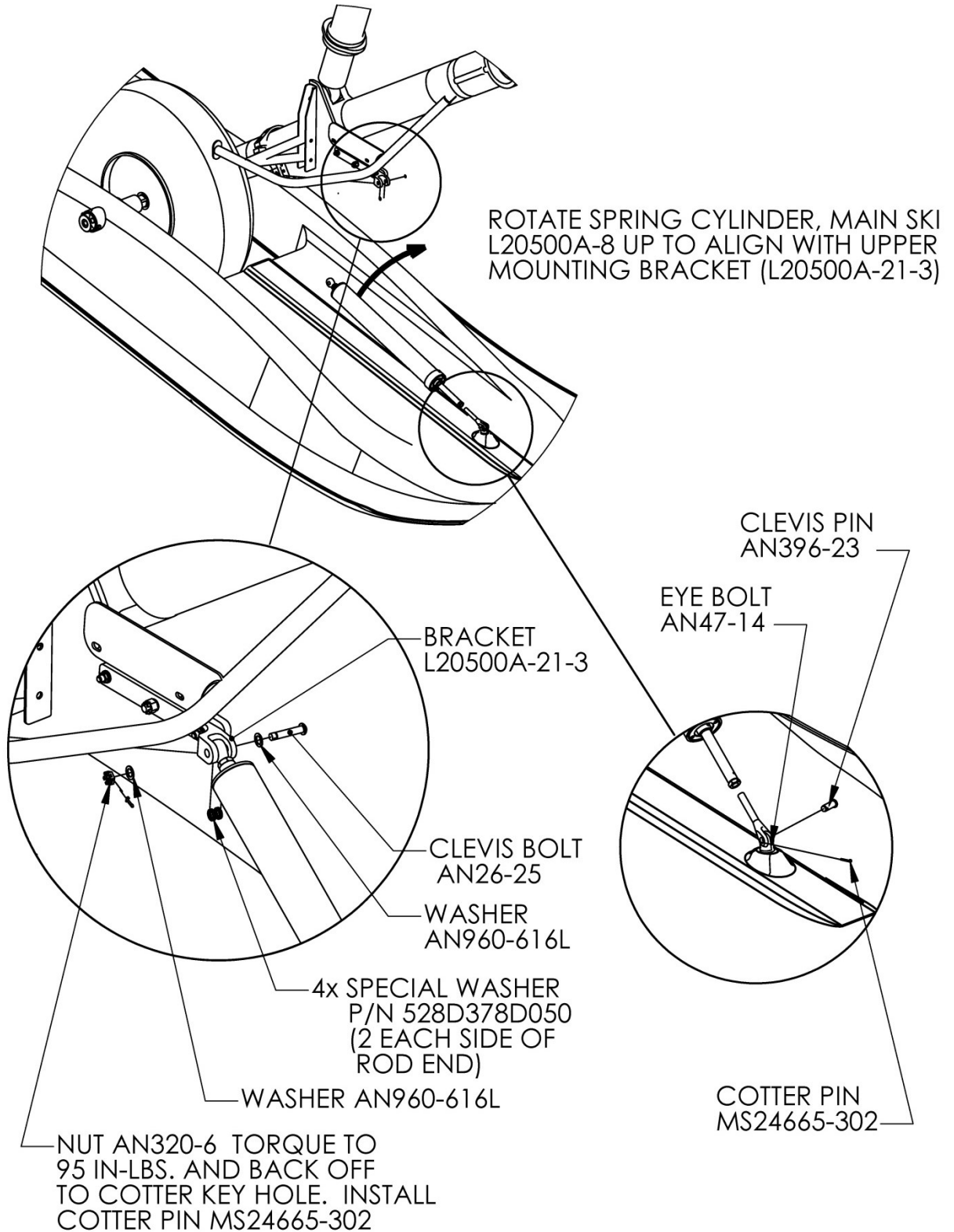

Figure 5.3

MAIN SKI – CHECK CABLE ASSEMBLY

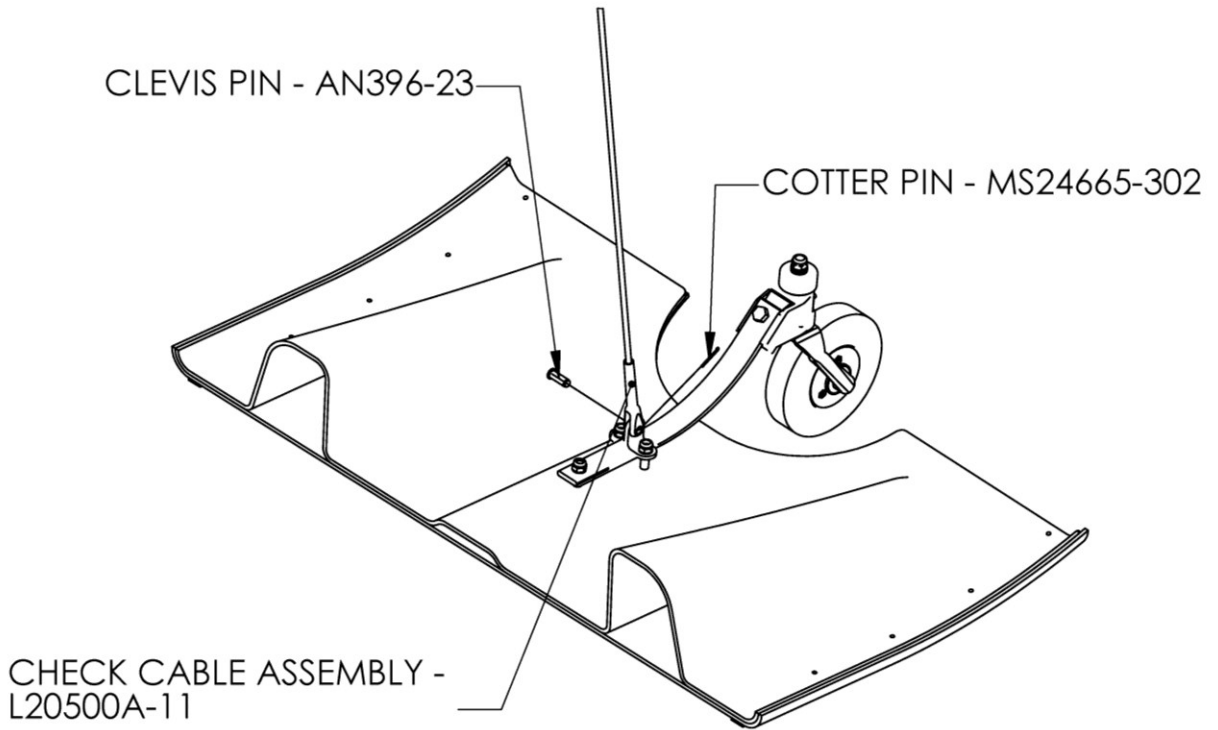

Figure 5.4

MAIN SKI – SAFETY CABLE ASSEMBLY

NUT - AN365-524
TORQUE TO 100-140 IN-LBS.

WASHER - AN960-516L

SAFETY CABLE ASSEMBLY
L20500A-12

BOLT - AN5-6A

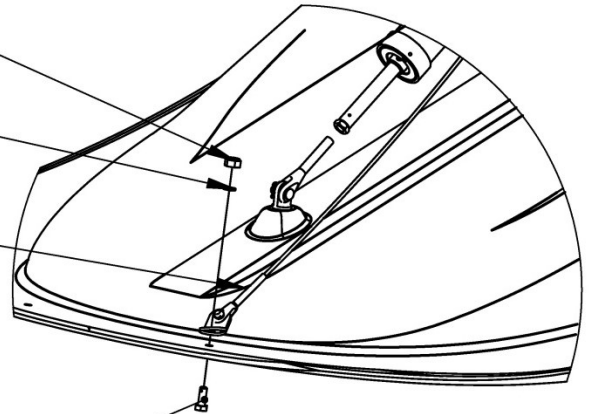

COTTER PIN – MS24665-302

EYE BOLT - AN45-11

BRACKET ASSEMBLY
L20500A-20 (L20500A-21)

CLEVIS PIN - AN395-17

SAFETY CABLE ASSEMBLY
L20500A-12

Figure 5.5

PYLON CHECK CABLE BRACKET INSTALL

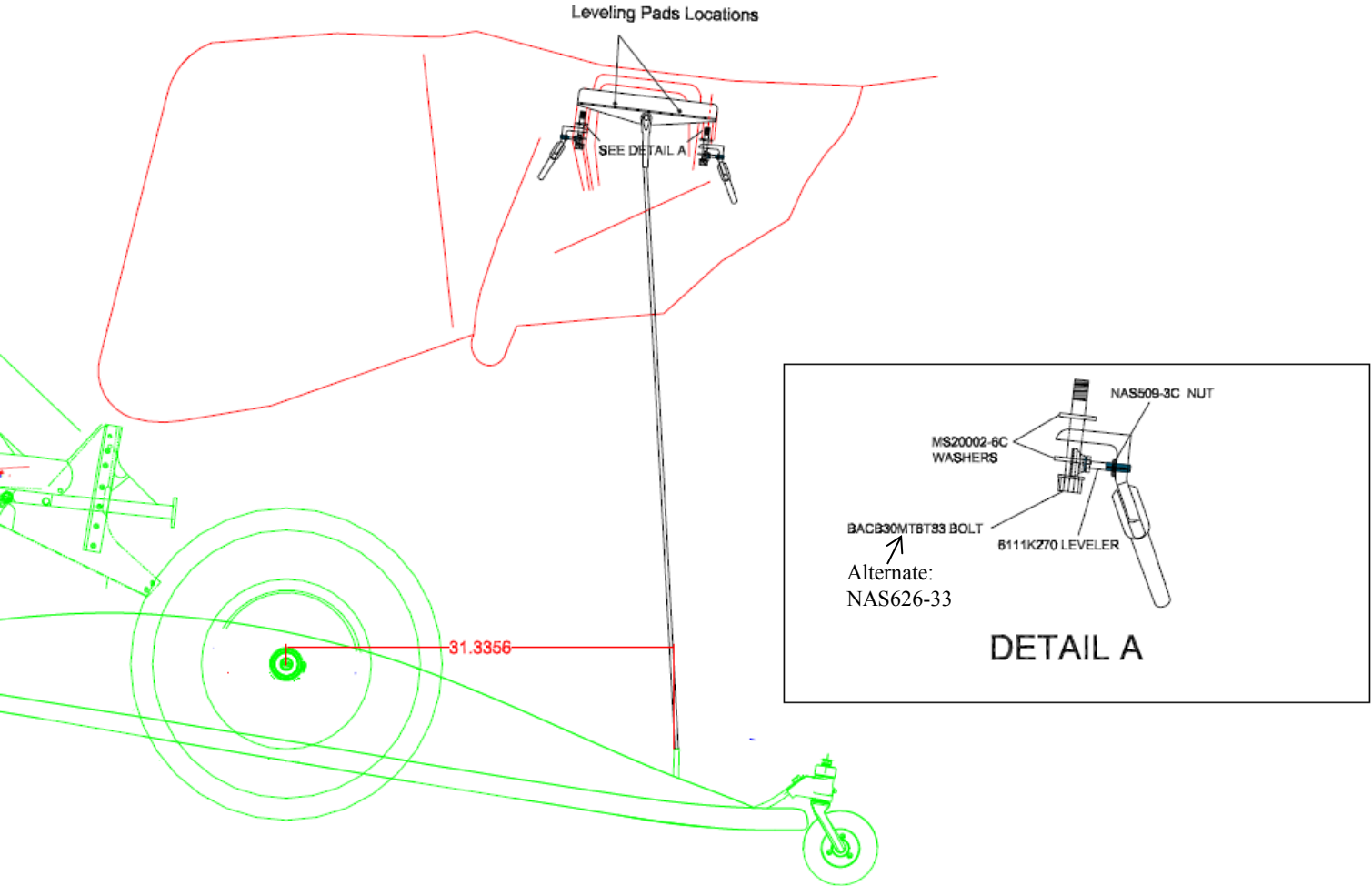

FIGURE 5.6

TAIL SKI – AXLE LOCATION AND ASSEMBLY

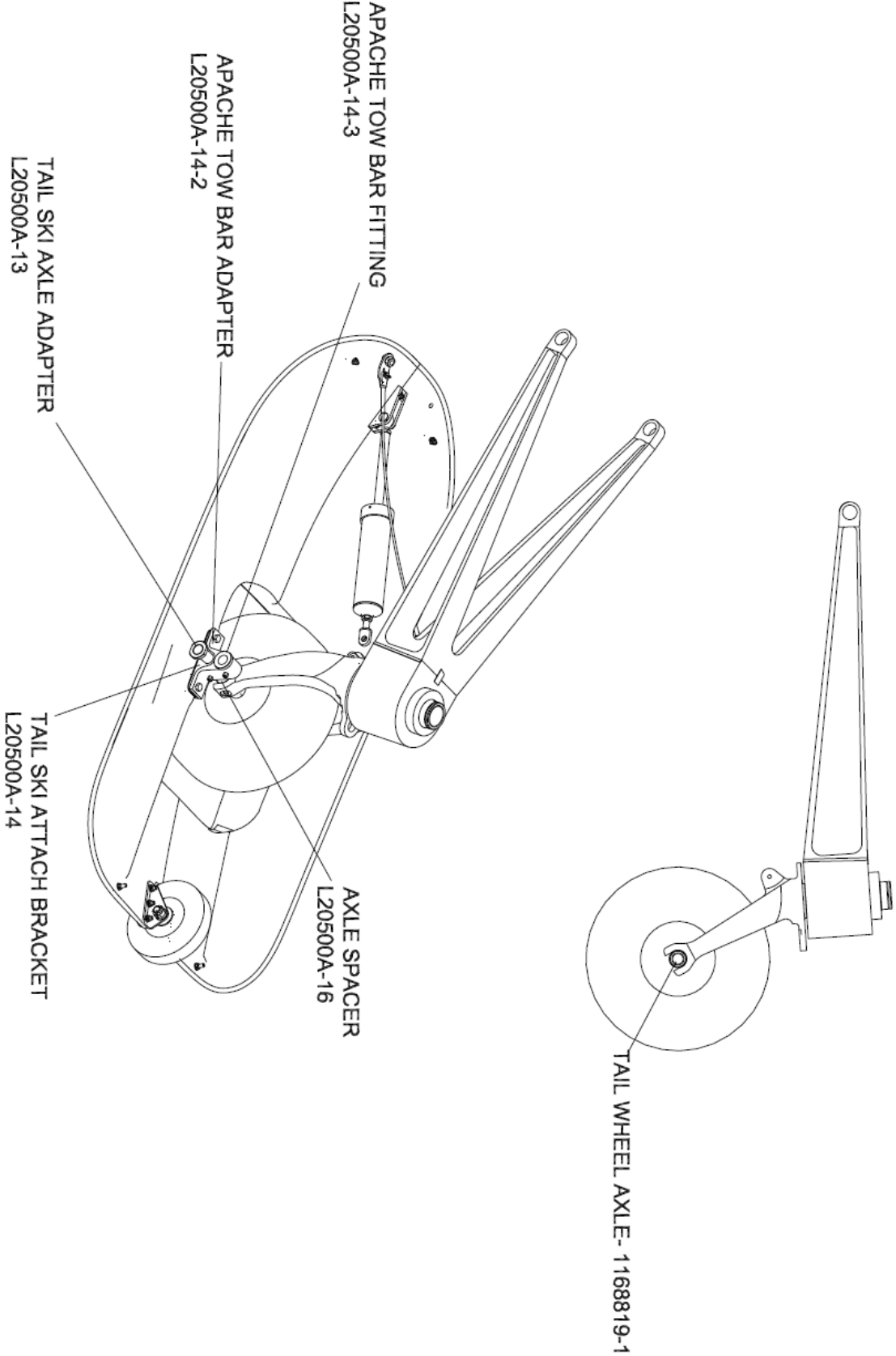

FIGURE 6.0

TAIL SKI – AXLE LOCATION AND ASSEMBLY

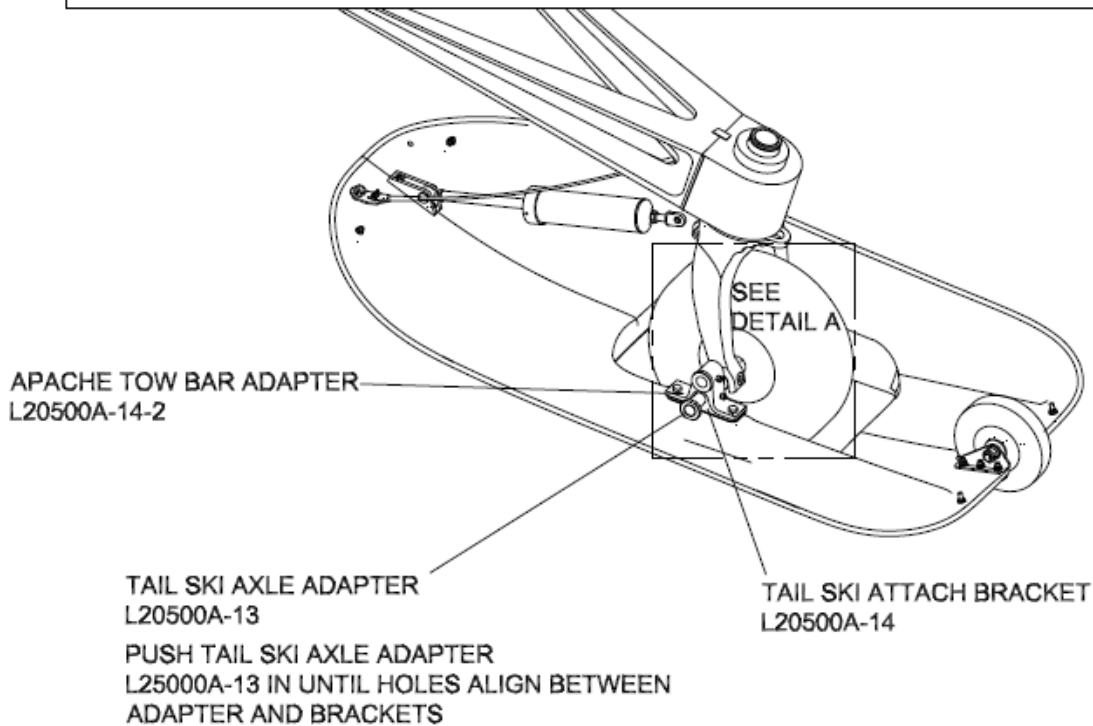
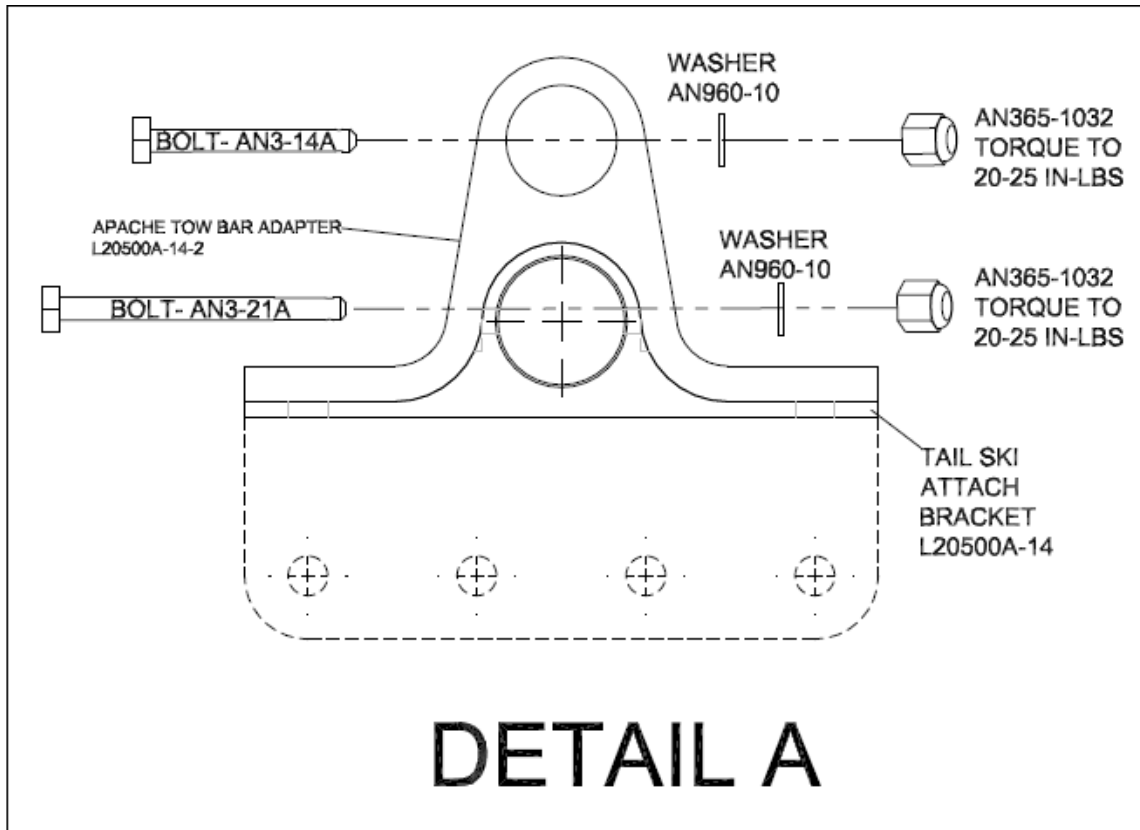

FIGURE 6.1

TAIL SKI – SPRING CYLINDER POSITIONING AND ASSEMBLY

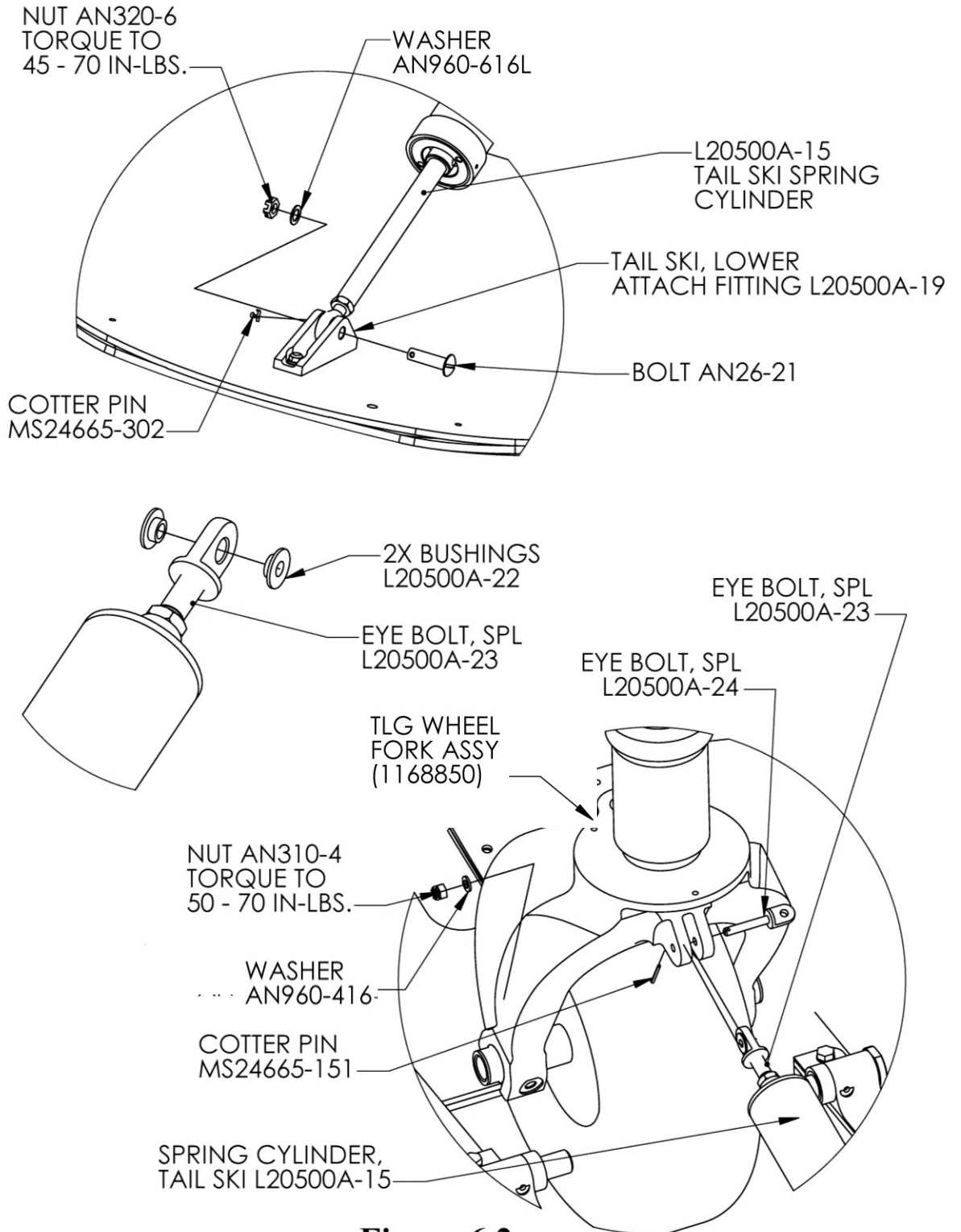

Figure 6.2

TAIL SKI – SAFETY CABLE ASSEMBLY

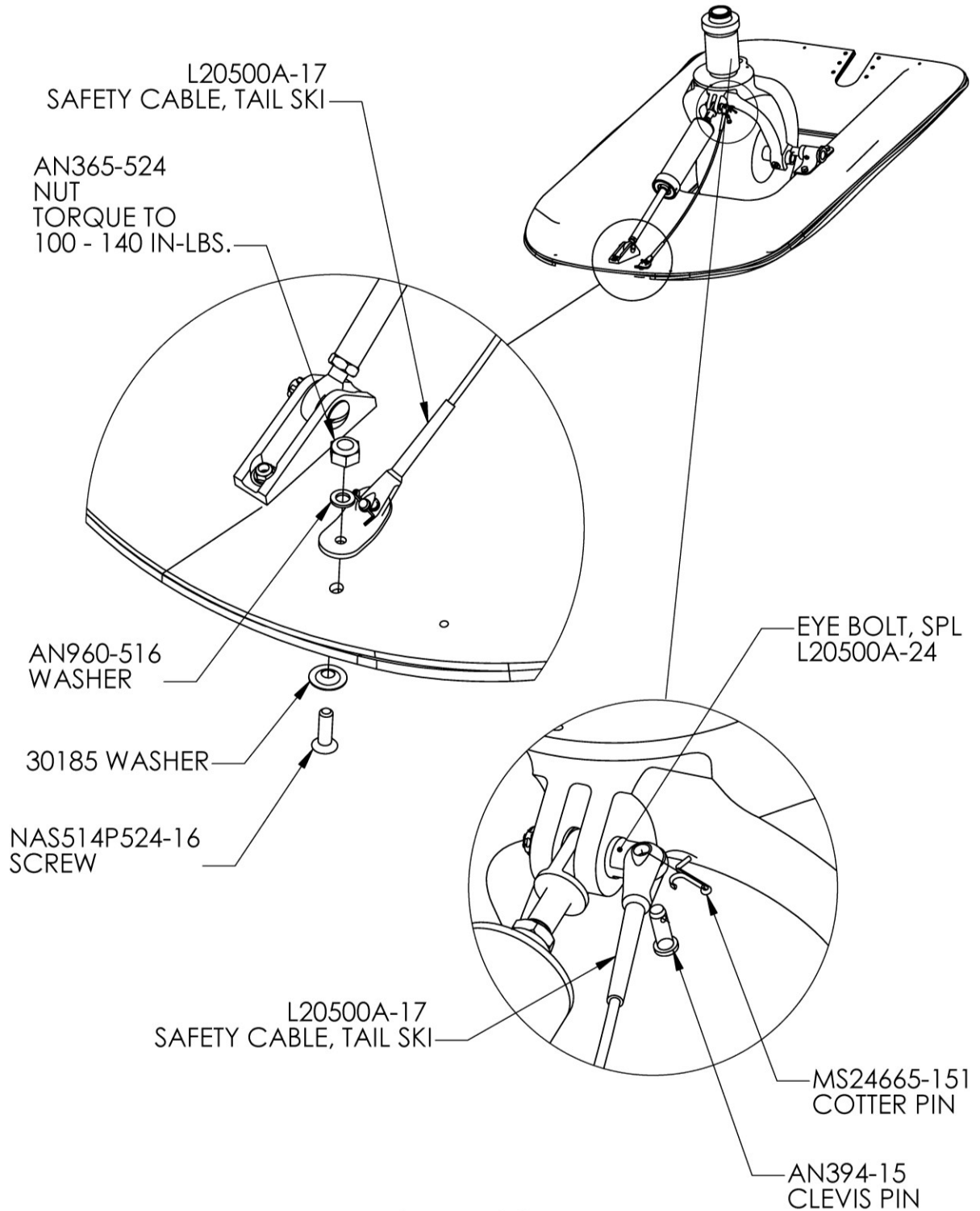

Figure 6.3

MAINTENANCE AND INSPECTION CRITERIA

Section 7.0 MAINTENANCE AND GROUND HANDLING RESTRICTIONS

1. **DO NOT** – Push or Pull on skis to move aircraft
2. **DO NOT** – Subject to flame or high heat
3. **DO NOT** - Attempt to jack aircraft with skis installed
4. **DO NOT** – Subject to harsh solvents or caustic chemicals
5. **DO NOT** – Use skis as a tie down for the aircraft
6. **DO NOT** – Disassemble the Main Ski Spring Cylinder (Airglas Part No.# L20500A-8)
7. **DO NOT** – Disassemble the Tail Ski Spring Cylinder (Airglas Part No.# L20500A-15)
8. **DO NOT** – Attempt to change a main gear tire with the skis installed
9. **DO NOT** – Attempt to change a tail gear tire with the skis installed
10. **DO NOT** – Use standard wheel chocks with skis installed

Section 8.0 MAINTENANCE OPERATIONAL CHECKS

10-14 Check (10 hour or 14 day inspection)

1. **CHECK** – Force required to move main ski tail wheel (Airglas Part No. # L20500-D501A) sideways, force shall be 3-5 lbs (22.24 Newtons).
2. **CHECK**- Main landing gear skis (if installed) inspect for cracks, excessive wear, fractures and abrasions. Security of spring cylinders. Main ski safety and check cables for security (Airglas Part No.# L20500A-12-1) & (Airglas Part No.# L20500A-11).
3. **CHECK** – Main landing gear ski tail wheel spring for damage and security (Airglas Part No. # L20500-D501A).
4. **CHECK**- Tail landing gear skis (if installed) inspect for cracks, excessive wear, fractures and abrasions. Security of the spring cylinder (Airglas Part No. # L20500A-15, Boeing Part No.# 7-511210303-003). Security of the safety cable No. (Airglas Part No. # L20500A-17). Security of the tail wheel assembly (Airglas Part No. # L20500-18).

Section 9.0 INSPECTION CRITERIA

500-Annual (500 hour or Annual inspection)

1. **INSPECT** – The main landing gear ski (Airglas Part No.# L20500A-01) for excessive cracks, wear, fractures and abrasions. Inspect the bottom for cracks, scratches and excess wear. If damaged consult manufacturer. Lubricate tail wheel fittings with SuperLube Synthetic Grease (PTFE).
2. **INSPECT** – The tail landing gear ski (Airglas Part No.# L20500A-03) for excessive cracks, wear, fractures and abrasions. Inspect the bottom for cracks, scratches and excess wear. If damaged consult manufacturer. Lubricate tail wheel fittings with SuperLube Synthetic Grease (PTFE).
3. **INSPECT** – The main landing gear safety cable (Airglas Part No.# L20500A-12) for integrity and fraying. The main landing gear check cable (Airglas Part No.# L20500A-11) for integrity and fraying. The main landing gear spring cylinder (Airglas Part No.# L20500A-8) for cracks, dents, wear, fractures and abrasions. The main landing gear bracket assembly (Airglas Part No.# L20500A-20 & 21) for integrity, cracks, dents and excessive wear.
4. **INSPECT**- The tail landing gear ski safety cable (Airglas Part No.# L20500A-17) for integrity and fraying. The tail landing gear spring cylinder (Airglas Part No.# L20500A-15) for cracks, dents, wear, fractures and abrasions.
5. **INSPECT**- The main landing gear ski axle (Airglas Part No.# L20500A-7 for cracks, dents and fractures. The main landing gear ski axle assemblies (Airglas Part No.# L20500A-5 and L20500A-6) for cracks, dents, fractures and thread integrity.
6. **INSPECT** –The tail landing gear ski axle adapters (Airglas Part No.# L20500A-13) for cracks, dents and fractures. The two (2) special eyebolts (Airglas Part No.#'s L20500A-24 & L20500A-23) for cracks and integrity.

MAINTENANCE TASKS

Section 10.0 MAINTENANCE TASKS

10.1 TOP SURFACE MAINTENANCE

The surface of the ski has a very durable plastic coating that is not affected by gas or oil or environmental conditions. It may be brightened up with rubbing compound and wax occasionally but should not require painting. (NOTE) Small hairline crack marks may appear in this coating at stress points. These do not affect the strength of the ski in any way and ARE NOT to be considered cracks as they are only in the surface coating and don't extend into the laminate.

10.2 BOTTOM SURFACE MAINTENANCE

1. The Teflon urethane coating allows maximum sliding in all snow conditions. No wax is required. Additional coats may be applied by brush or spray when necessary.
2. When bottom surface becomes excessively scratched or worn, it may be sanded down with a small belt or disc sander and re-coated with a brush application of the graphite filled epoxy resin coating 4B2. This is allowed to cure at room temperature and is then roughed up. Then it is coated with a Teflon urethane coating. A kit for this process is obtainable from manufacturer. If major repairs are necessary, manufacturer can advise on proper procedure.

TYPES OF POSSIBLE DAMAGE

A.) Negligible damage

1. Small nicks, scratches or abraded areas in top or bottom of ski.

B.) Repairable damage

1. **Cracks or fractures** - except in area of ski bushing or spring cylinder attach points. Airglas should be consulted on repairs in this area.
2. **Delamination** - except in area of ski bushing and spring cylinder attach points. Airglas should be consulted on repairs in this area.
3. **Small holes** - max. 2" dia.
4. **Abrasion** - bottom wear due to contact with rocks etc., bottom coatings worn through to glass fibers.
5. **Demolished section** - if under 30% of the area of the ski and it must be confined to forward or aft 1/3 of ski. Consult Airglas for repair.
6. **Major bottom damage** - complete new or partial bottom may be factory installed.

C.) DAMAGE NECESSITATING REPLACEMENT

1. Major damage in area of ski bushings.
2. Damage to more than 30% of area of top of ski. This could be a combination of cracks, fractures, delamination, and demolished sections. This type of damage would be caused from a crash.

1 2 3 4

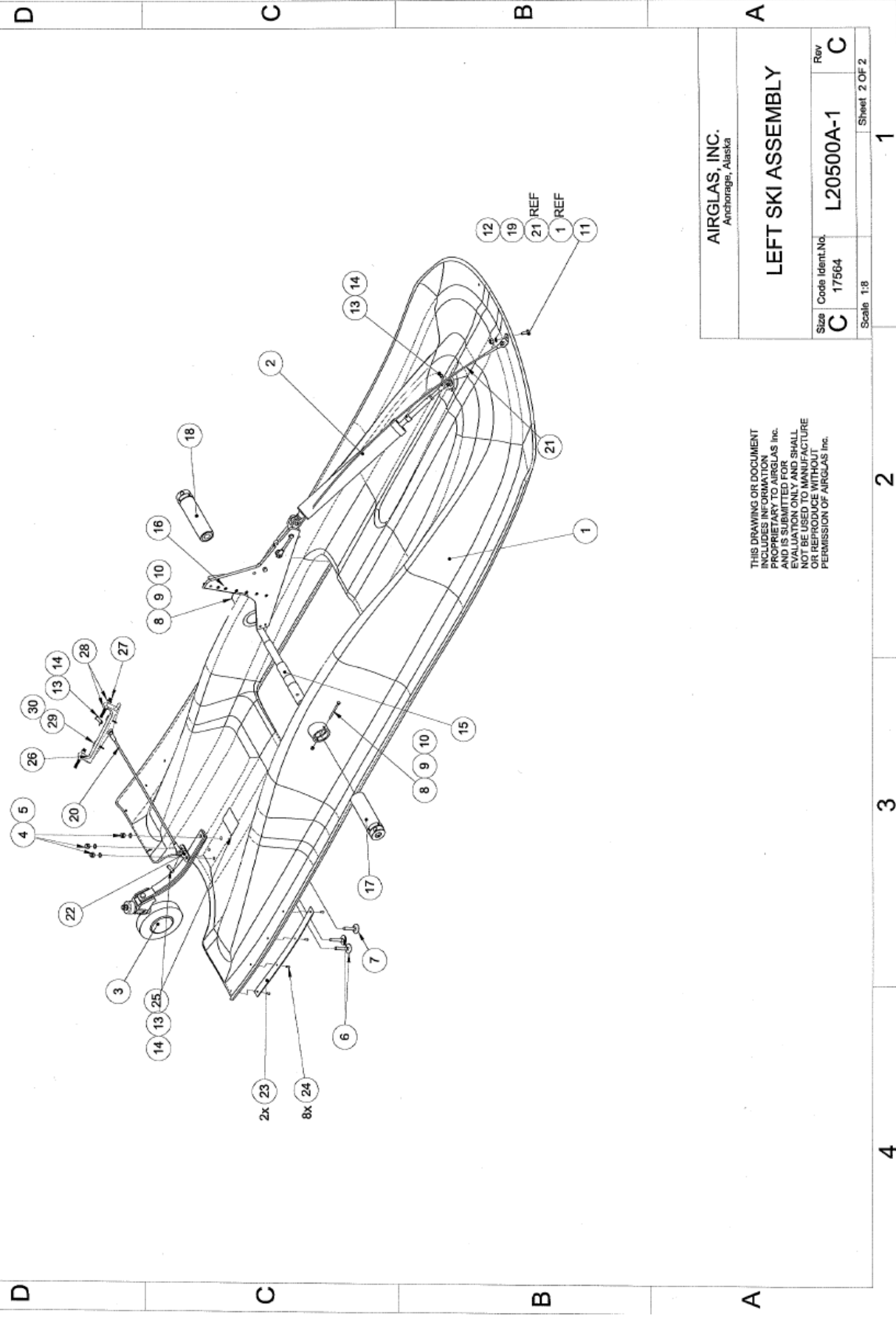

REV	ECN	DESCRIPTION	APPROVED BY	DATE
A	1100-00	REPLACE 1/2" DIA. PIN, CONNECTED	WKL	8-Jan-04
B		ADJUST CHECK CABLE BRACKET & HARDWARE	JRH	4-Feb-04
C				4-Aug-15

AIRGLAS, INC.
Anchorage, Alaska

LEFT SKI ASSEMBLY

Size	Code Ident. No.	Rev
C	17564	L20500A-1
Scale	1:8	Sheet 2 OF 2

THIS DRAWING OR DOCUMENT
INCORPORATES THE AIRGLAS
PROPERTY AND IS SUBMITTED FOR
EVALUATION ONLY AND SHALL
NOT BE USED TO MANUFACTURE
OR REPRODUCE WITHOUT
PERMISSION OF AIRGLAS, INC.

1 2 3 4

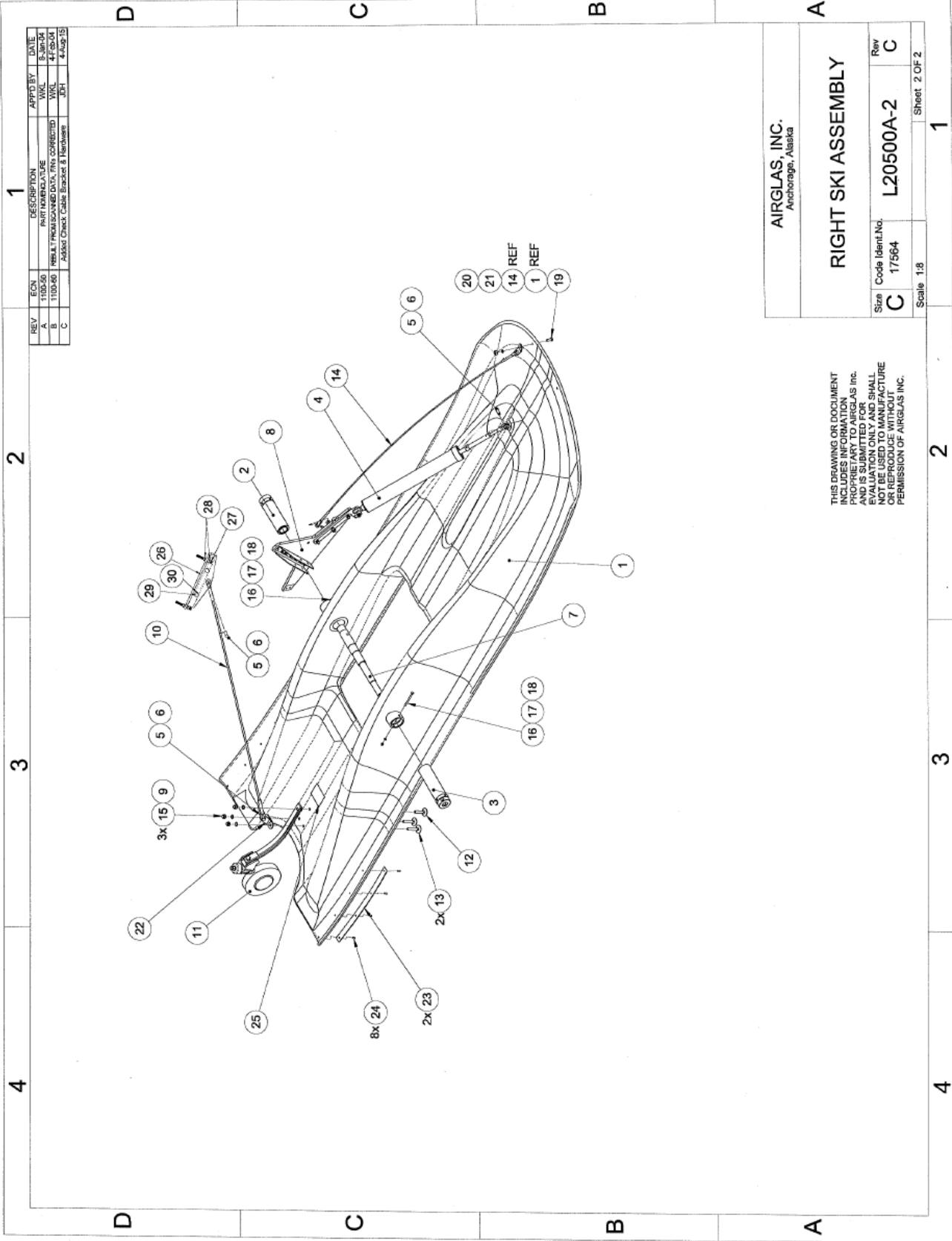

REV	ESN	DESCRIPTION	APPROV BY	DATE
A	110040	REPLAINT PROVISIONED DATA, PINS CORRECTED	WJK	4/15/04
B	110040	ADD Check Cable Bracket & Hardware	JEN	4-Aug-15
C				

AIRGLAS, INC.
Anchorage, Alaska

RIGHT SKI ASSEMBLY

Size	Code Ident.No.	Rev
C	L20500A-2	C
Scale 1:8		Sheet 2 OF 2

THIS DRAWING OR DOCUMENT
INCLUDES INFORMATION
PROPRIETARY TO AIRGLAS, INC.
NO PART OF THIS DOCUMENT
IS TO BE REPRODUCED OR
EVALUATION ONLY AND SHALL
NOT BE USED TO MANUFACTURE
OR REPRODUCE WITHOUT
PERMISSION OF AIRGLAS, INC.

REV	ECN	DESCRIPTION	APPRO BY	DATE
A	110050	PART MANUFACTURE	WKL	8-10-04
B	110050	REBUILT PER SPECIFICATIONS	WKL	4-18-04
C	110050	Added Check Cable Bracket & Hardware	JSH	4-Aug-05

NOTES: UNLESS OTHERWISE SPECIFIED

- MATERIAL: SEE BELOW
- ASSEMBLE PER MASTER PROCESS-SPEC 1001-L20500A-01
- ON PLACARD DOT PEEN, ETCH OR ENGRAVE THE FOLLOWING:
 - MODEL "1 20500A"
 - PART NO "L20500A-2"
 - SERIAL NO "XXXX"
 - DATE MFG "XXXX"
 - MANUFACTURE "8V613SDCN7-511210300-102_RH_SKI_KIT"

NO.	QTY	CODE IDENT-NO	PART NO.	DESCRIPTION	STOCK SIZE	MATERIAL	MATERIAL SPEC.	WEIGHT/LBS	FINISH	ZONE
1	1	17564	L20500A-01	MAIN SKI						
2	1	17564	L20500A-5	AXLE ASSY, INBOARD						
3	1	17564	L20500A-6	AXLE ASSY, OUTBOARD						
4	1	17564	L20500A-8	SPRING CYLINDER, MAIN SKI						
5	3		MS24665-302	COTTER PIN						
6	3		AN398-21	CLEVIS PIN						
7	1	17564	L20500A-7	AXLE, MAIN LANDING GEAR						
8	1	17564	L20500A-20	BRACKET ASSEMBLY						
9	3		AN960-616I	WASHER						
10	1	17564	L20500A-11	CHECK CABLE						
11	1	17564	L20500-D501HD	TAIL WHEEL ASSY (Heavy Duty)						
12	1	17564	EB616-20	ELEVATOR BOLT						
13	2	17564	EB616-21	ELEVATOR BOLT						
14	1	17564	L20500A-12	SAFETY CABLE ASSY						
15	3		AN363-616	NUT						
16	2		AN3-27A	BOLT						
17	2		AN960-10	WASHER						
18	2		AN365-1032	NUT						
19	1		AN5-6A	BOLT						
20	1		AN365-524	NUT						
21	1		AN960-516L	WASHER						
22	1	17564	L20500A-11-1B	SKI ANGLE BRACKET, R.H.						
23	2	17564	L20500-44	MAIN SKI RUNNER						
24	8		SSB6-10	RIVET						
25	1	17564	L10500A-11-3	Check Cable Bracket						
26	1	17564	BAC800M1633	BOLT						
27	2		MS20002-6C	WASHER, BEVELED						
28	4		6111K270	SS LEVELER						
29	2		NAS509-3C	NUT						
30	2									

UNLESS OTHERWISE SPECIFIED DIMENSIONS ARE IN INCHES	CONTRACT NO.
TOLERANCES EXCEPT AS NOTED	SPEC. CONTROL NO.
DECIMALS ± .005	
FRACTIONS ± .005	
ANGLES ± .1°	
PITCHING ± 1/64"	

APPROVED BY	DATE
WKL	8-10-04
JSH	4-Aug-05

RIGHT SKI ASSEMBLY

AIRGLAS, INC.
Anchorage, Alaska

Scale 1:8

Sheet 1 OF 2

Size Code Ident.No. L20500A-2

Rev C 17564

REV	ECO	DESCRIPTION	DATE
B	110601	RESULT FROM SCANNED DATA FILE CORRECTED	4-29-04

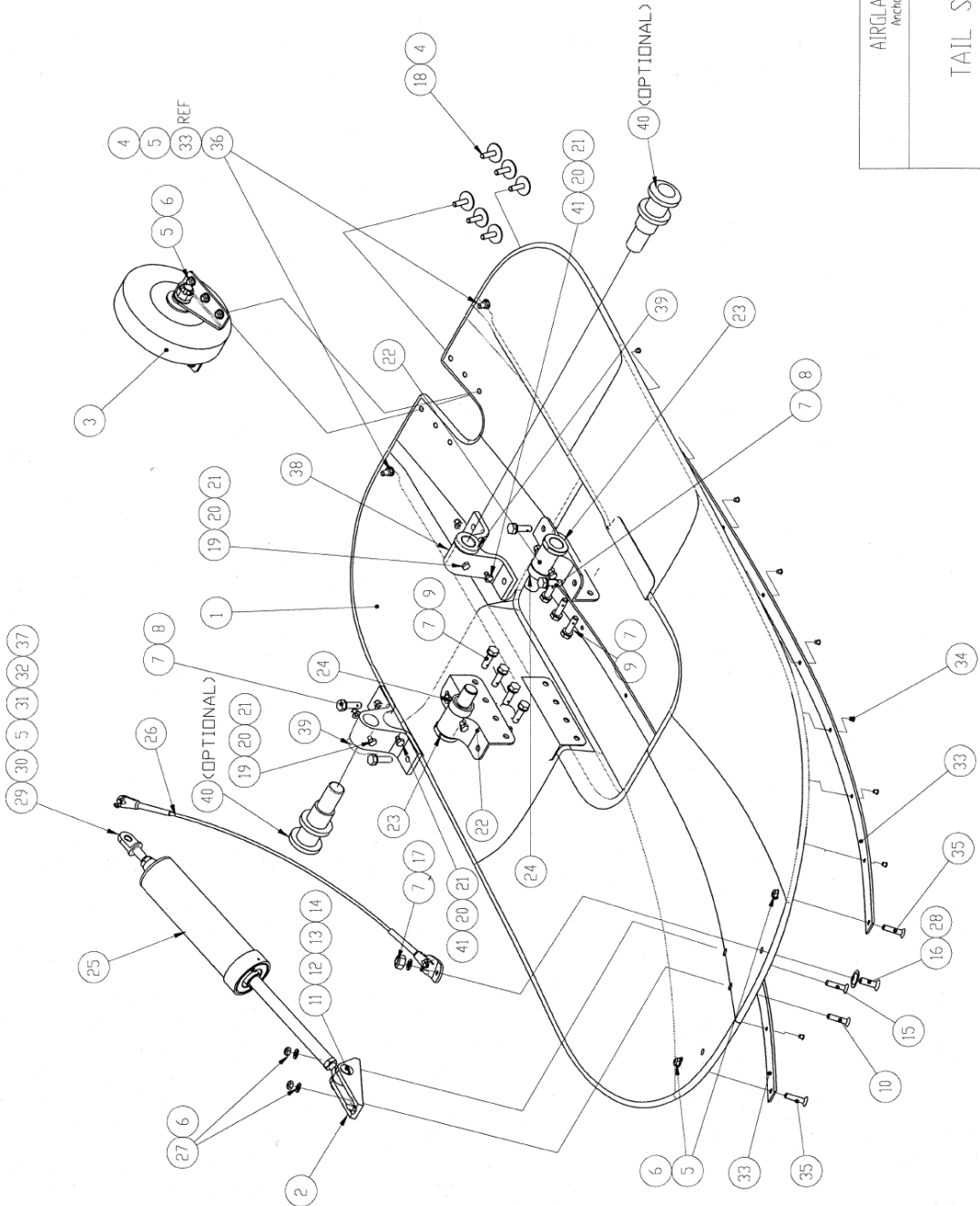

AIRGLAS, INC.
Anchorage, Alaska

TAIL SKI ASSEMBLY

Size	Code Ident.No.	Rev	Sheet
C	L20500A-3	B	2 OF 2
Scale 1:4			1

REV	ECN	DESCRIPTION	APPD BY	DATE
A	110020	REBUILD FROM EXISTING DATA, P/N'S CORRECTED	WKL	2-JUN-04
B			WKL	4-FEB-04

NOTES: UNLESS OTHERWISE SPECIFIED

- MATERIAL: SEE BELOW
- ASSEMBLE PER MASTER PROCESS-SPEC 1001-L20500A-03

1

2

3

4

NO	QTY	CODE-IDENT-NO	PART-NO	DESCRIPTION	STOCK SIZE	MATERIAL	MATERIAL SPEC.	WEIG-FILES	FINISH	ZONE
1	1	17664	L20600A-03	TAIL SKI ASSEMBLY						
2	1	17664	L20600A-19	TAIL SKI LOWER ATTACH FITTING						
3	1	17664	L20600-18	TAIL WHEEL BRACKET KIT						
4	6		MS2465-04	WASHER						
5	11		AN604-16	WASHER						
6	12		AN66-428A	NUT						
7	13		AN60-516	WASHER						
8	4		AN6-12A	BOLT						
9	8		AN6-10A	BOLT						
10	1		AN609-416R-18	SOREW						
11	1		AN66-21	CLEVIS BOLT						
12	1		AN60-616L	WASHER						
13	1		AN60-6	NUT						
14	1		MS2465-302	COTTER PIN						
15	1		AN609-416R-20	SOREW						
16	1		MS614F324-16	SOREW						
17	1		AN66-524	NUT						
18	6		AN4-7A	BOLT						
19	2		AN6-14A	BOLT						
20	4		AN66-10	WASHER						
21	4		AN66-1032	NUT						
22	2	17664	L20600A-14	TAIL SKI ATTACH BRACKET						
23	2	17664	L20600A-13	TAIL SKI AXLE ADAPTER						
24	2	17664	L20600A-16	AXLE SPACER						
25	1	17664	L20600A-15	SPRING CYLINDER TAIL SKI						
26	1	17664	L20600A-17	SAFETY CABLE TAIL SKI						
27	2		AN60-416L	WASHER						
28	1	17664	30185	WASHER						
29	2	17664	L20600A-22	BUSHING						
30	1		AN610-4	NUT						
31	1		MS2465-151	COTTER PIN						
32	1	17664	L20600A-24	EYE BOLT SFL						
33	2	17664	L20600-43	TAIL SKI RUNNER						
34	16		SS66-6	RVET						
35	2		AN609-416R-16	SOREW						
36	2		AN609-416R-14	SOREW						
37	1	17664	L20600A-23	EYE BOLT SFL						
38	2	17664	L20600A-14-2	APACHE TOWBAR ADAPTER						
39	2	17664	L20600A-14-3	APACHE TOWBAR FITTING						
40	2	17664	L20600A-14-4	UHF STYLE TOWBAR FITTING (OPTIONAL)						
41	2		AN6-21A	BOLT						

	CONTRACT NO.	AIRGLAS, INC. Anchorage, Alaska	
	SPEC. CONTROL NO.		
UNLESS OTHERWISE SPECIFIED DIMENSIONS ARE IN INCHES TOLERANCES EXCEPT AS NOTED			
DECIMALS	XX ± .03	ANGLES	X ± 5°
FRACTIONS	XX ± .005		
	± 1/64		
THIS DRAWING IS DOCUMENT INCORPORATED INTO THE PRELIMINARY TO AIRGLAS, INC. AND IS SUBMITTED FOR EVALUATION ONLY AND SHALL NOT BE USED TO MANUFACTURE OR REPRODUCE WITHOUT PERMISSION OF AIRGLAS, INC.		Approved by: WKL	
L20500A	AH-640	Checked by: DL	
NEXT ASSY.	USED ON	Drawn by: PCSI	
APPLICATION		Date: Sept. 22, 2003	

	Scale 1/4"	Sheet 1 OF 2	
TAIL SKI ASSEMBLY		Size C	Code Ident No. L20500A-3
		Rev B	

NOTE: SKI SHOULD BE REMOVED FROM AIRCRAFT TO COMPLETE THIS PROCEDURE.

STEP 1

TAIL WHEEL RE-INFORCEMENT PROCEDURE

REMOVE TAIL WHEEL AND ALL ATTACH HARDWARE. ELEVATOR BOLTS (EB616-21's) ARE REMOVED BY TAPPING OUT WITH A RUBBER Mallet.

REMOVE ALL TAIL WHEEL HARDWARE

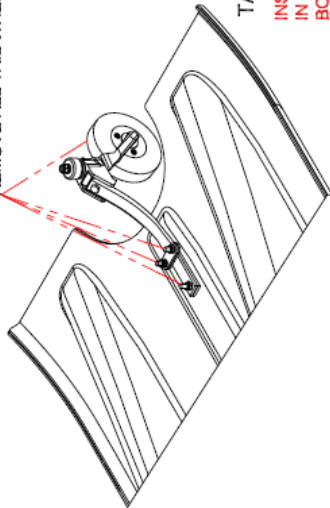

STEP 2

TAIL WHEEL RE-INFORCEMENT PROCEDURE

INSERT NEW EB616-24 BOLTS INTO AFT HOLES, EB616-22 IN FORWARD HOLE. MAKE SURE SQUARED HOLE AND BOLTS ARE ALIGNED. TAP IN FROM THE BOTTOM OF SKI. USE A DEAD BLOW OR SIMILAR TYPE HAMMER TO INSTALL BOLTS COMPLETELY.

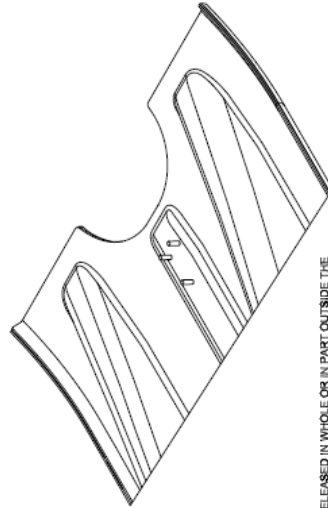

STEP 3

TAIL WHEEL RE-INFORCEMENT PROCEDURE

STACK NEW L20500-D501A-6 (MODIFIED) SPRING SEGMENT ON TOP OF ORIGINAL SPRINGS. RE-INSTALL ALL HARDWARE. YOU MAY BE REQUIRED TO TAP ON BOLTS TO GET THE HOLES TO ALIGN TO THE L20500A-11-1A or B. INSTALL CHECK CABLE TO L20500-11-1A or B. USE WASHERS AS REQUIRED TO ADJUST GRIP. TORQUE TO 160-185 IN LBS.

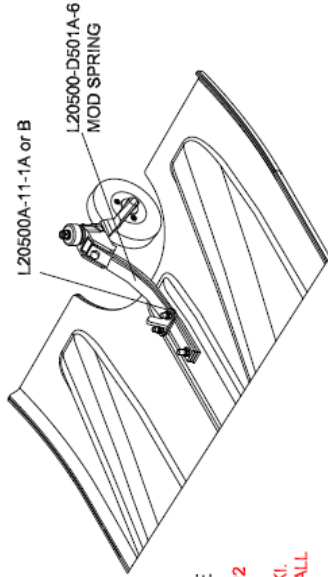

*THIS TECHNICAL DATA SHALL NOT, WITHOUT THE WRITTEN PERMISSION OF AIRGLAS, INC. BE EITHER (A) USED, RELEASED IN WHOLE OR IN PART, OUTSIDE THE GOVERNMENT, (B) USED IN WHOLE OR PART BY THE GOVERNMENT FOR MANUFACTURE OR (C) USED BY A PARTY OTHER THAN THE GOVERNMENT, EXCEPT FOR: (1) EMERGENCY REPAIR OR OVERHAUL WORK ONLY, OR FOR THE GOVERNMENT, WHERE THE ITEM OR PROCESS CONCERNED IS NOT OTHERWISE REASONABLY AVAILABLE TO ENABLE TIMELY PERFORMANCE OF THE WORK, PROVIDED THAT THE RELEASE OR DISCLOSURE HEREOF OUTSIDE THE GOVERNMENT, AS THE INTEREST OF THE UNITED STATES MAY REQUIRE, ONLY FOR INFORMATION OR EVALUATION WITHIN SUCH LIMITED CIRCUMSTANCES AS MAY BE DETERMINED BY THE GOVERNMENT UNDER THE CONDITION OF ABOVE. THIS LEGEND SHALL BE MARKED ON ANY REPRODUCTION HEREOF IN WHOLE OR PART.

AIRGLAS, INC. ANCHORAGE, ALASKA L20500-D501A-6 L20500-D501A-6 RE-INFORCEMENT PROCEDURE		DRAWING NO. L20500-D501A-6	APPROVED BY: [Signature] CHECKED BY: [Signature] DRAWING DATE: 11/18/81	DATE: 3 MAR 14 SHEET NO.: 2 OF 2
--	--	-------------------------------	---	-------------------------------------

REMOVAL OF SKISPROCEDURE

The best method to remove the L20500A Ski kit is to remove the Tail Ski (L20500A-3) first.

Tail Ski Removal Procedure:

1. Remove Bolts (AN4-7A), Washers (AN960-416), and Nuts (A365-428), (and NAS70C-4 Washers) holding tail ski, Tail Wheel Bracket Kit (L20500-18) to ski and remove Tail Wheel Bracket Kit. *See Figure 2.0* (retain hardware)
2. Remove Cotter pin (MS24665-151), Washer (AN960-416) and Nut (AN310-4) from Eye Bolt (L20500A-24) attached to TLG wheel fork assembly lugs 1168850.
3. Hold the Spring Cylinder in one hand, lift the front of the ski, and remove the L20500A-24 from TLG lug. Retain the upper Spring Cylinder Eye Bolt (L20500A-23) and Bushings. After removal from the TLG lug, loosely reinstall the L20500A-24 back into the L20500A-23 Eyebolt, using the Washer (AN960-416) and Nut (AN310-4). Note: The Safety cable (L20500A-17) can remain attached to eyebolt (L20500A-24) for storage. *See Figure 6.2*
4. Remove Bolt(s) (AN3-21A) lower bolts of Apache Tow Bar Adapter (L20500A-14-2). Retain Bolt, Washer(s) (AN960-10) and Nut(s) (AN365-1032). *See page 29& 30 of Manual for Breakdown of parts*
5. Remove Tail Ski Axle Adapter(s) (L20500A-13) from Ski Attach Bracket(s), remove Axle Spacer(s) (L20500A-16) on Tail Ski Axle Adapter(s). *See page 29& 30 of Manual for Breakdown of parts*
6. Remove Ski Axle Adapter (s) (L20500A-13) from Tail Ski Axle. Use care in holding up ski during this step.
7. Once ski is completely removed from tail landing gear, connect tow vehicle to standard axle location.
8. Tow helicopter backwards until the wheel rolls over and out of tail ski.
9. Re-Install Tail Wheel Bracket Kit (L20500-18) onto tail ski. *See Figure 2.0*
10. Reinstall a Wire Strike (Deflector) onto Tail Landing Gear using all hardware identified in Helicopters Illustrated Parts Breakdown (IPB).

Main Ski Removal Procedure:

NOTE: Preparation of both skis is the same except where noted.

11. Remove Tail Wheel Assembly and Check Cable from rear of the Main Ski by removing Elevator Bolts (EB616-20, EB616-21) from the bottom of the ski *See figure 1.1* Save all hardware for future use.
12. Remove bolt(s) (AN3-27A) from Inboard and Outboard Axles and Ski Bushing. Retain Washer(s) (AN960-10) and Nut(s) (AN365-1032) onto bolt(s) *See Figure 5.2*.
13. Remove Spring Cylinder, Main Ski (L20500A-8) from Upper Mounting Bracket (L20500A-21-3), retain Clevis Bolt (AN26-25), (2) Washers (AN960-616L) and Nut (AN320-6), (4) Special Washers (P/N 528D378D050 (2 each side of rod end). *See Figure 5.3*
14. Remove upper end of Safety Cable Assy. (L20500A-12) from to Eye Bolt (AN45-11) at 2nd hole back on Bracket Assy. (P/N L20500A-20, L20500A-21) Retain clevis pin (AN395-17) and cotter pin MS249665-302. *See Figure 5.5*
15. Completely remove Axle Assy's., Inboard & Outboard (L20500A-5 & L20500A-6) from Main Ski Bushing Assy. (L20500-4) . Lift Rear of ski to take weight off of axles. *See Figure 5.1* Note: Assistance will be needed to support ski during this operation.
16. Remove Check Cable (L20500A-11) from check cable bracket, PN L20500A-11-3 by removing Clevis Pin and Cotter Pin.
17. Install Airglas installation ramps on both main skis. Ensure all attachments to gear are removed.

18. Tow helicopter or push helicopter aft with help of assistants until the main wheels are completely outside of skis. CAUTION – To avoid damage to ski take extreme care to ensure that the wheels are on the outboard part of the wheel wells. *See Figure 5.0*
19. Re-Install Tail Wheel Assembly (L20500-D501A) *See Figure 1.1*
20. Once ski is removed, continue to remove other hardware as needed. If skis are only removed for maintenance or other issues, all remaining hardware can remain installed on helicopter.

RETURNING AIRCRAFT TO ORIGINAL CONFIGURATION (WITHOUT SKIS)

21. Remove Axle (L20500A-7) from Trailing Arm (1168320-101). Remove bolt, and slide axle out by rotating and pulling on it. Retain existing hardware for later install of Jack Pad (1168321-1) . *See Figure 3.2*
22. Install Jack Pad (1168321-1) and align with Trailing Arm (1168320-101), using hardware from Step 21 above. Torque to value given in Figure 3.2
23. Remove both inboard pylons.
24. Remove inboard attach bolts and check cable bracket (L20500-11-3).
25. Install original HS6170V6-22 bolts back into inboard pylon.
26. Re-install pylon. Match torque of existing pylon bolts.
27. Remove Step Assembly (7-511113527-1 & -2). Keep existing hardware for future use. *See figure 3.0.*
28. Remove Airglas Bracket Assembly (L20500A-20 R.H., L20500A-21 L.H.) to Main Landing Gear, retain existing hardware *See Figure 3.1*
29. Install Wire Cutter Assembly (443-83020-2). *See figure 3.0*, Bolt Wire Cutter to Clamp (443-83023-1) (both sides) using existing hardware from Step 28. *See Figure 3.1*
30. Re-install Step Assembly (7-511113527-1 & -2) to Wire Cutter Assembly using existing hardware from Step 27. *See Figure 3.1 inboard* .