



AIRGLAS INSTALLATION,
MAINTENANCE, SERVICE
INSTRUCTIONS & ILLUSTRATED PARTS
LIST (IMSIPL) MANUAL

MODEL L20500A SKI KIT

CODE IDENT NO. 17564

23 April, 2019

THIS MANUAL INCLUDES INFORMATION PROPRIETARY TO AIRGLAS, INC. AND SHALL
NOT BE USED TO MANUFACTURE OR REPRODUCE WITHOUT PERMISSION OF
AIRGLAS, INC.

AIRGLAS, INC
ANCHORAGE, ALASKA 99507

TABLE OF CONTENTS

Equipment & Materials	1
Section 1.0 Ski - Preparation Main Landing Gear	2
Section 2.0 Ski - Preparation Tail Landing Gear	2
Section 3.0 Helicopter - Preparation Main Landing Gear	2
Section 4.0 Helicopter - Preparation Tail Landing Gear	3
Section 5.0 Tail Ski - Installation	3
Section 6.0 Main Ski - Installation	4
Figure 1.0 Main Ski – Ski Preparation for Assembling to AH-64D	5
Figure 1.1 Main Ski – Ski Preparation for Assembling to AH-64D	6
Figure 2.0 Tail Ski – Ski Preparation for Assembling to AH-64D	7
Figure 3.0 Main Gear – Boeing Step and Plate Removal	8
Figure 3.1 Main Gear – Airglas Bracket and Step Assembly	9
Figure 3.2 Main Gear – Jack Pad Removal / Axle Assembly	10
Figure 5.0 Main Gear / Tail Gear – Pre-Install Ski Position	11
Figure 5.1 Main Ski – Axle Positioning and Assembly	12
Figure 5.2 Main Ski – Axle Positioning and Assembly	13
Figure 5.3 Main Ski – Spring Cylinder Positioning and Assembly	14
Figure 5.4 Main Ski – Check Cable Assembly	15
Figure 5.5 Main Ski – Safety Cable Assembly	16
Figure 5.6 Main Ski Check Cable Installation	17
Figure 6.0 Tail Ski – Axle Location and Assembly	18
Figure 6.1 Tail Ski – Axle Location and Assembly	19
Figure 6.2 Tail Ski – Spring Cylinder Positioning and Assembly	20
Figure 6.3 Tail Ski – Safety Cable Assembly	21
Section 7.0 Maintenance and Ground Handling Restrictions	22
Section 8.0 Maintenance Operational Checks	22
Section 9.0 Inspection Criteria	22
Section 10.0 Maintenance Tasks	23
Section 11.0 Ski Removal	30

EQUIPMENT AND MATERIALS

INITIAL SETUP

PERSONNEL REQUIRED

- One: AH-64 Helicopter Repairer
- One: Aircraft Structural Repairer
- Three: Assistants

MATERIALS/PARTS

- Corrosion Preventative Compound, MIL-C-16173D, Grade 2
- Dry Cleaning Solvent, MIL PRF-680 Type II
- SuperLube Synthetic Grease (PTFE)
- Readily Available Anti-Seize agent
- Rag, Clean, DDD-T-541

TOOLS

- Aircraft Mechanic's Tool Kit
- Torque Wrench, 0 – 600 in. lbs, GGG-W-686

LANDING GEAR SKIS - INSTALL MAIN AND TAIL

SKI - PREPARATION MAIN LANDING GEAR

Section 1.0

Preparation of both skis is the same except where noted.
Right side is shown.

1. Remove and save hardware (AN3-27A bolt, AN960-10 Washer, and AN365-1032 Nut) holding the Axle Assy., Outboard (L20500A-6) in place. *See figure 1.0*
2. Slide Axle Assy., Outboard out of fitting in ski. *See figure 1.0*
3. Remove Shipping Tube covering the Axle, Main Landing Gear (L20500A-7). *See figure 1.0*
4. Remove the Axle (L20500A-7) *See figure 1.0*
5. DO NOT REMOVE AXLE ASSY., INBOARD. *See figure 1.0*
6. Remove Tail Wheel Assembly and Check Cable from rear of the Main Ski by removing Elevator Bolts (EB616-20, EB616-21) from the bottom of the ski *See figure 1.1* Save all hardware for future use.

SKI - PREPARATION TAIL LANDING GEAR

Section 2.0

7. Remove Tail Wheel Bracket Kit (L20500-18) from back of Tail Ski Assy. (L20500A-3). Save all hardware for future use. *See Figure 2.0*
8. Remove Tail Ski Axle Adapter (L20500A-13). Save all hardware for future use *See Figure 2.0*

HELICOPTER - PREPARATION MAIN LANDING GEAR

Section 3.0

Preparation of both skis is the same except where noted.
Right side is shown.

9. Remove Step Assembly (7-511113527-1 & -2). Keep existing hardware for future use. *See figure 3.0.*
10. Remove Wire Cutter Assembly (443-83020-2). Keep hardware and wire cutter assy. for future use. *See figure 3.0*
11. Attach Airglas Bracket Assembly (L20500A-20 R.H., L20500A-21 L.H.) to Main Landing Gear using existing hardware *See Figure 3.1* TORQUE VALUE
12. Bolt Bracket Assembly to Clamp (443-83023-1) (both sides) using existing hardware from Step 10. *See Figure 3.1*
13. Re-install Step Assembly (7-511113527-1 & -2) to Bracket Assembly (L20500A-20, L20500A-21) using existing hardware from Step 9. *See Figure 3.1inboard*
14. Remove Jack Pad (1168321-1). Keep existing hardware. *See Figure 3.2*
15. Slide Axle, Main Landing Gear (L20500A-7) into the Trailing Arm (1168320-101) axle housing. *See Figure 3.2*
16. Line up clearance hole on Axle (L20500A-7) with clearance hole on Trailing Arm (1168320-101).
17. Re-install existing hardware from Step 14 to hold Axle (L20500A-7) in place. *See Figure 3.2* TORQUE VALUE
18. Remove both inboard pylons.
19. Remove inboard attach bolts
20. Install check cable attach bracket PN L20500A-11-3, see fig. 5..6
21. Match torque of existing pylon bolts.
22. Set levelers to make full contact with side of pylon. Tighten NAS509-3C and safety the two nuts.

REMOVAL OF STEP AND WIRE CUTTER

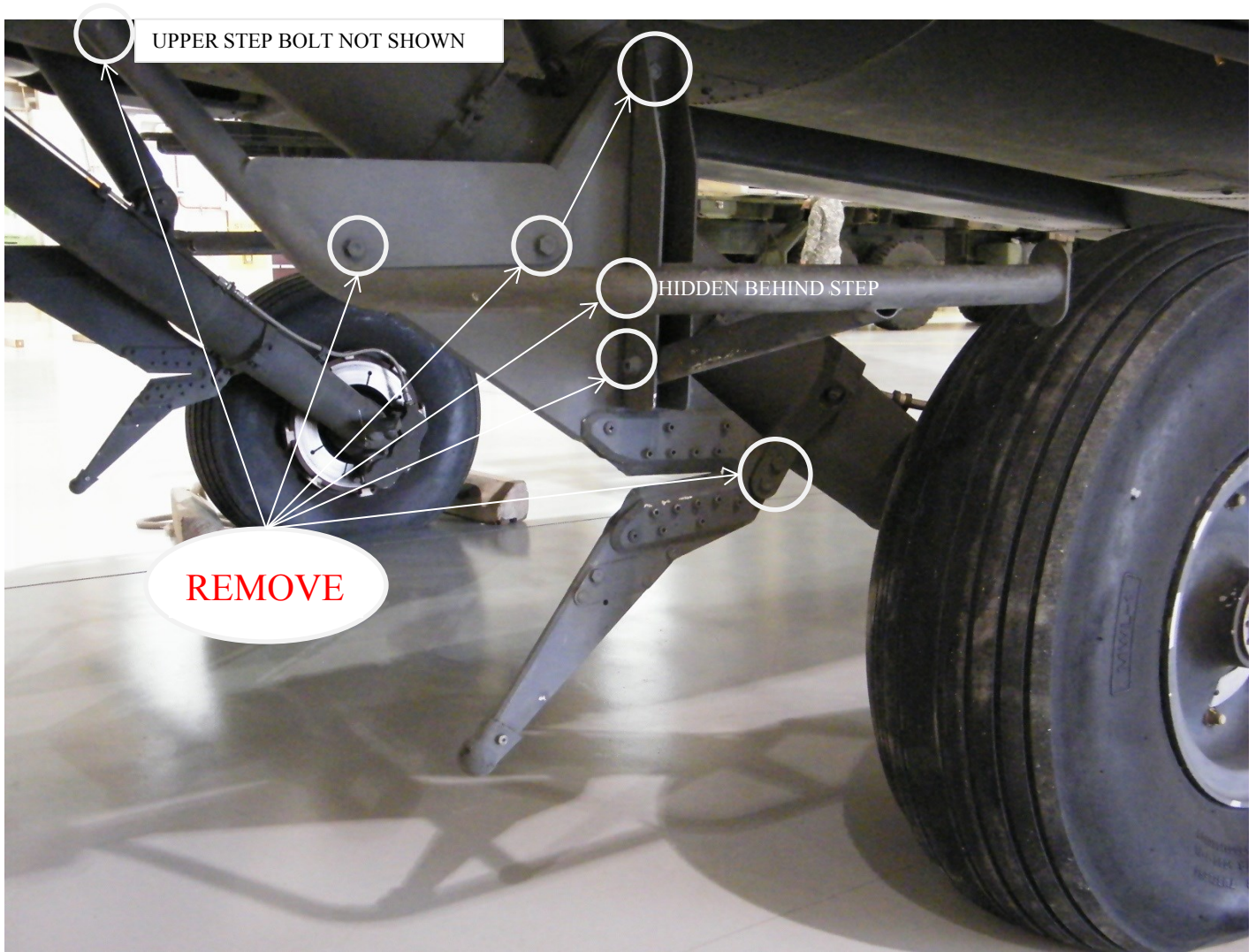

REMOVE HARDWARE CIRCLED IN PICTURE. NOTE: ONE OF THE FASTENERS IS HIDDEN BEHIND THE STEP, ONE (UPPER STEP BOLT) IS NOT IN PICTURE.

NOTE: RETAIN ALL HARDWARE FOR LATER USE.

**INSTALLATION OF AIRGLAS ADAPTER ASSEMBLY
(L20500A-20 RH SIDE. L20500A-21 LH Side)**

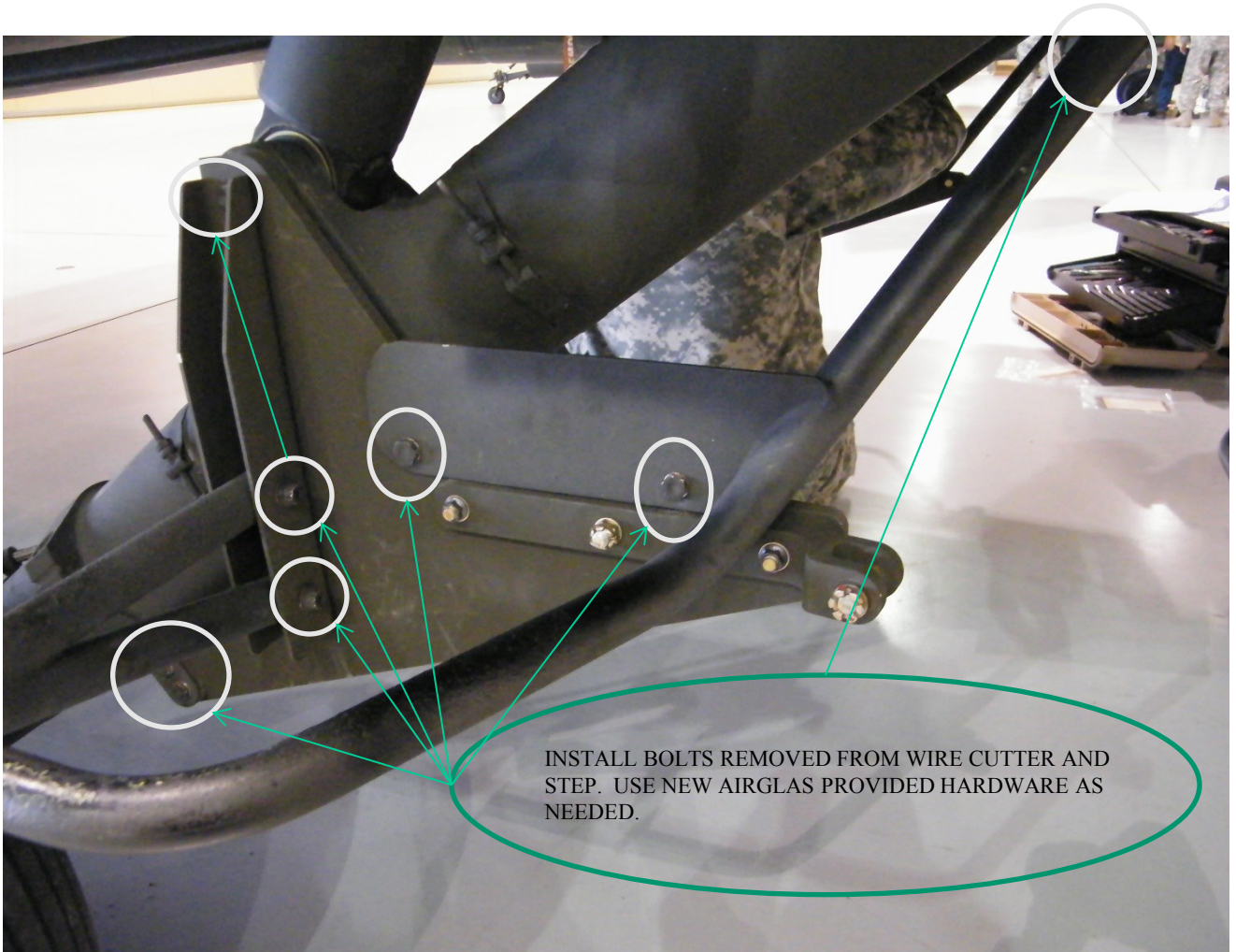

SEE FIG 3.1 FOR SPECIFIC DETAILS ON HARDWARE AND TORQUE REQUIREMENTS

REMOVE JACK PAD



JACK PAD IS INSTALLED WITH ONE BOLT. REMOVE BOLT AND THEN TWIST AND PULL ON PAD TO REMOVE.

AFTER REMOVAL OF JACK PAD, CLEAN THE INTERIOR OF THE AXLE CAVITY TO REMOVE ALL FOREIGN MATERIAL. USE OF A ROUND (BORE) BRUSH AND SHOP AIR WILL BE NEEDED.

INSERT L20500A-7 AXLE INTO MAIN LANDING GEAR AXLE CAVITY.

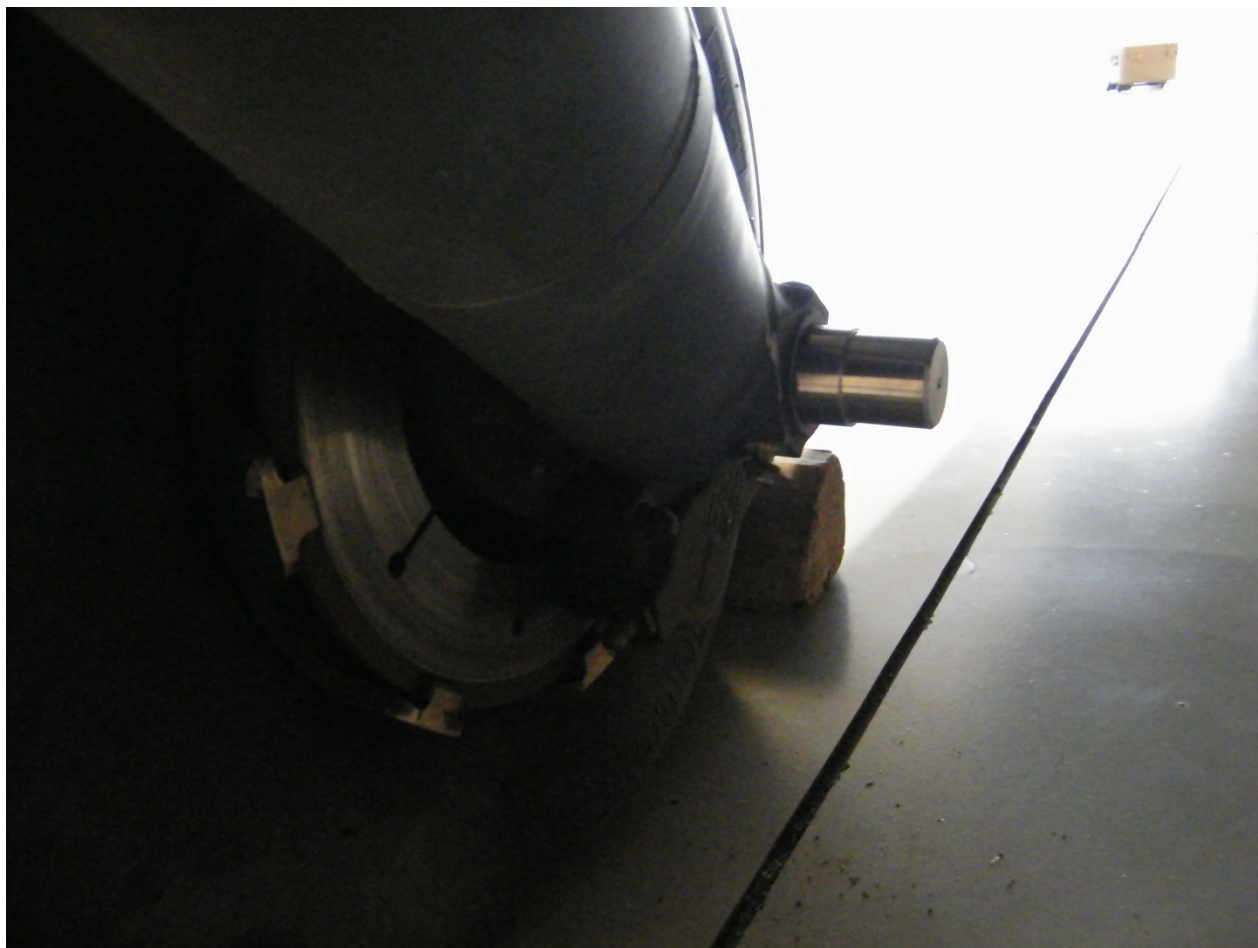

INSERTION OF THE AIRGLAS L20500A-7 AXLE CAN HAVE BE COMPLICATED BY PAINT OVERSPRAY INSIDE AXLE CAVITY. BOEING DID NOT SPECIFY A PAINT THICKNESS IN THIS AREA. DO A TEST INSERTION TO SEE HOW FAR AXLE WILL GO IN WITH NO FORCE. IF IT DOES NOT GO IN ALL THE WAY, TAP LIGHTLY WITH A RUBBER MALLET.

NOTE: BE SURE TO ALIGN HOLES OF THE AIRGLAS AXLE (L20500A-7) AND THE MAIN LANDING GEAR AXLE.

YOU MAY NEED TO DO A SERIES OF INSERTIONS AND PAINT CHIP REMOVAL TO GET AXLE TO GO ALL THE WAY IN. IF YOU SEE ANY METALLIC CHIPS, STOP AND HAVE IT ASSESSED BY A TECHNICAL EXPERT.

HELICOPTER - PREPARATION TAIL LANDING GEAR

Section 4.0

23. Remove Wire Strike (Deflector) from Tail Landing Gear and all associated hardware.

NOTE: The bolts that attach wire strike to tail wheel axle will need to be replaced with NAS6405-32 bolts, or an alternate temporary method by using a washer stack added to replace the thickness of the wire strike attach lugs. Washers should be replaced at the next major maintenance inspection. These bolts are in shear, so washer stack has no impact on joint strength.

TAIL SKI - INSTALLATION

Section 5.0

24. Remove Bolts (AN4-7A), Washers (AN960-416), and Nuts (A365-428), (and NAS70C-4 Washers) holding tail ski, Tail Wheel Bracket Kit (L20500-18) to ski and remove Tail Wheel Bracket Kit. *See Figure 2.0* (retain hardware)

Note: Remove the L20500A-14-2 bracket (Item 38 of IPB on Page 28) prior to towing helicopter onto tail ski. This bracket will create interference with tow bar. This is done by removing the two AN5-12A bolts and one AN3-21A bolt (Item 8 & 41 on page 28) attaching bracket to the L20500A-14 (Item 22 on page 28)

25. Center Tail Ski in front of Tail Gear Wheel. *See Figure 5.0*
26. Tow helicopter, or push helicopter forward, with help of assistants, until Tail Wheel is centered in Ski Wheel Well.
27. Lift rear ski so the Tail Ski Attach Brackets (L20500A-14) line up with the Tail Wheel Axle (1168819-1). *See Figure 6.0*

Note: Re-install the L20500A-14-2 bracket (Item 38 of IPB on Page 28) attaching bracket to the L20500A-14 (Item 22 on page 28) This is done by installing the two AN5-12A bolts and one AN3-21A bolt (Item 8 & 41 on page 28) removed in Step 24 above. Torque AN5-12A to 100-140 IN LBS, the AN3-21A to 20-25 IN LBS.

28. Insert Tail Ski Axle Adapter(s) (L20500A-13) through Ski Attach Bracket(s), place Axle Spacer(s) (L20500A-16) on Tail Ski Axle Adapter(s). *See Figure 6.0*
29. Push Ski Axle Adapter (s) into Tail Ski Axle until clearance holes line up on Ski Attach Bracket(s) and Ski Axle Adapter (s). *See Figure 6.1*
30. Insert Bolt(s) (AN3-14A) through clearance holes, affix Washer(s) (AN960-10) and Nut(s) (AN365-1032). *See Figure 6.1* TORQUE VALUE
31. Attach Spring Cylinder, Tail Ski (L20500A-15) to Tail Ski, Lower Attach Fitting (L20500A-19) with Bolt (AN26-21), Washer (AN960-616L) and Nut (AN320-6). Secure Nut with Cotter Pin (MS24665-302). *See Figure 6.2* TORQUE VALUE
32. Insert Bushings (L20500A-22) into 3/8 hole in Eye Bolt, SPL (L20500A-23) one from each side. *See Figure 6.2*
33. Hold the Spring Cylinder in one hand, lift the front of the ski, and position the upper Eye Bolt (L20500A-23) so that the Eye Bolt is lined up with the Bushings and tlg wheel fork assy lugs 1168850. Insert Eye Bolt (L20500A-24) Affix Washer (AN960-416) and Nut (AN310-4). Instl MS24665-151 cotter pin. *See Figure 6.2*
34. Install Safety Cable Tail Ski (L20500A-17) onto Tail Ski using Washer (30185), Screw (NAS514P524-16), Washer (AN960-516) and Nut (AN365-524). *See Figure 6.3* TORQUE VALUE
35. Attach upper portion of Safety Cable to Eye Bolt (L20500A-24) using Clevis Pin (AN394-15) and Cotter Pin (MS24665-151). *See Figure 6.3*
36. Re-Install Tail Wheel Bracket Kit (L20500-18). *See Figure 2.0*

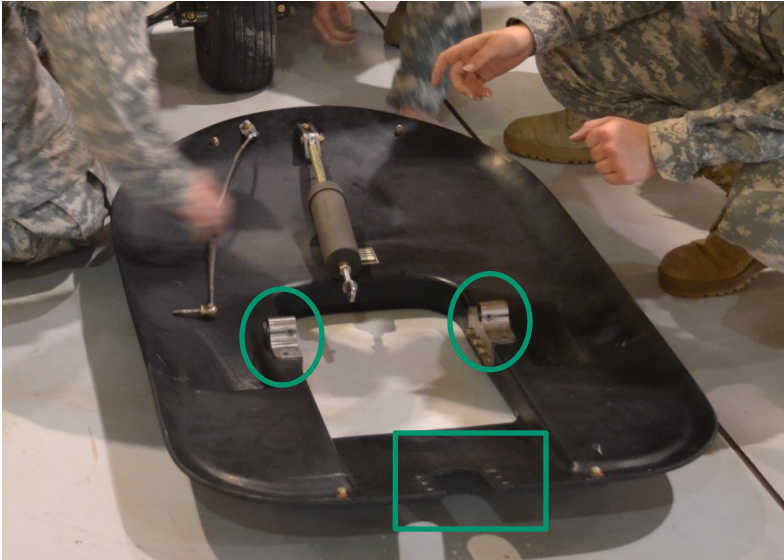

Tail ski with L20500A-14-2 Tow Bar Adapters and L20500-18 tail wheel assembly removed

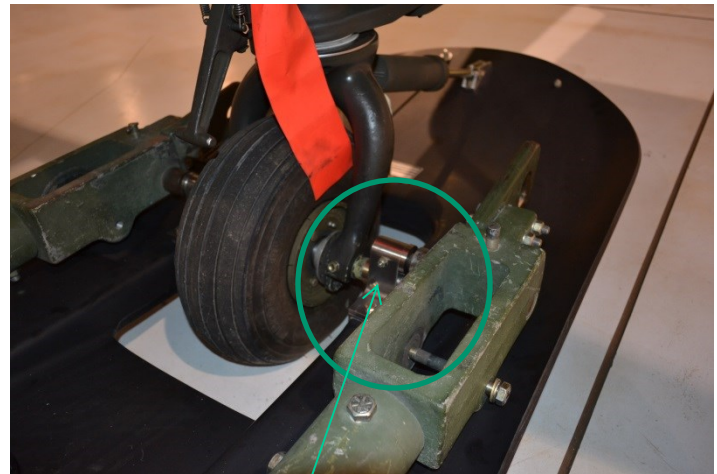

Tail ski with L20500A-14-2 Tow Bar Adapters reinstalled and connected to tow bar.



Tail ski with L20500A-14-2 Tow Bar Adapters reinstalled and L20500-18 tail wheel assembly being installed.

LANDING GEAR SKIS - INSTALL MAIN AND TAIL

MAIN SKI - INSTALLATION

Section 6.0

37. Center Main Skis in front of Main Landing Gear Wheels *See Figure 5.0*
38. CAUTION – To avoid damage to ski take extreme care to ensure that the wheels are on the outboard part of the wheel wells.
39. Install Airglas installation ramps on both main skis.
40. Tow helicopter or push helicopter forward with help of assistants until the main wheels are centered in the ski wheel well.
41. Lubricate Axle, Main Landing Gear (L20500A-7) with thin coat of Synthetic Grease (PTFE).
42. Lift tail of main ski off the ground and slide fore or aft to align the Axle Assembly, Inboard (L20500A-5) (which was left on the ski) with the Axle, Main Landing Gear (L20500A-7). Slide ski outboard until Axle (L20500A-7) is properly seated in Inboard Axle (L20500A-5). *See Figure 5.1*
43. Coat Axle Assy., Outboard (L20500A-6) threads with anti-seize agent. Coat Axle Assy., Outboard (L20500A-6) body with corrosion preventative compound, MIL-C-16173D, Grade 2.
44. Insert Axle Assy., Outboard (L20500A-6) into Main Ski Bushing Assy. (L20500-4) and thread Ski Axle into Ski Bushing. *See Figure 5.1*
45. Thread Inboard and Outboard Ski Axles until both are evenly seated on Axle, Main Landing Gear (L20500A-7). *See Figure 5.2*
46. Back off Inboard and Outboard Ski Axles until the holes line up to slots on the Ski Bushing.
47. Install bolt(s) (AN3-27A) through Inboard and Outboard Axles and Ski Bushing. Affix Washer(s) (AN960-10) and Nut(s) (AN365-1032) onto bolt(s) *See Figure 5.2*. TORQUE NUTS TO 20 – 25 INCH-POUND.
48. Install Spring Cylinder, Main Ski (L20500A-8) on forward Ski Eye Bolt (AN47-14) with Clevis Bolt (AN396-23) and Cotter Pin (MS24665-302) and to the Upper Mounting Bracket (L20500A-21-3) with Clevis Bolt (AN26-25), (2) Washers (AN960-616L) and Nut (AN320-6), (4) Special Washers (P/N 528D378D050 (2 each side of rod end). *See Figure 5.3* TORQUE VALUE
49. Install Check Cable (L20500A-11) to check cable bracket, PN L20500A-11-3 using Clevis Pin and Cotter Pin.
50. Re-Install Tail Wheel Assembly (L20500-D501A) *See Figure 1.1*
51. Align Check Cable to Ski Angle Bracket (L20500A-11-1A, L20500A-11-1B), Insert Clevis Pin (AN396-23) and Cotter pin (MS24665-302). *See Figure 5.4*
52. Install lower end of Safety Cable Assy. (L20500A-12) to ski with Bolt (AN5-6A) Washer (AN960-516L) Nut (AN365-524). *See Figure 5.5*. TORQUE VALUE Install upper end to Eye Bolt (AN45-11) at 2nd hole back on Bracket Assy. (P/N L20500A-20, L20500A-21) Fasten with clevis pin (AN395-17) and secure with cotter pin MS249665-302. *See Figure 5.5*.

MAIN SKI – SKI PREPARATION FOR ASSEMBLING TO AH-64D

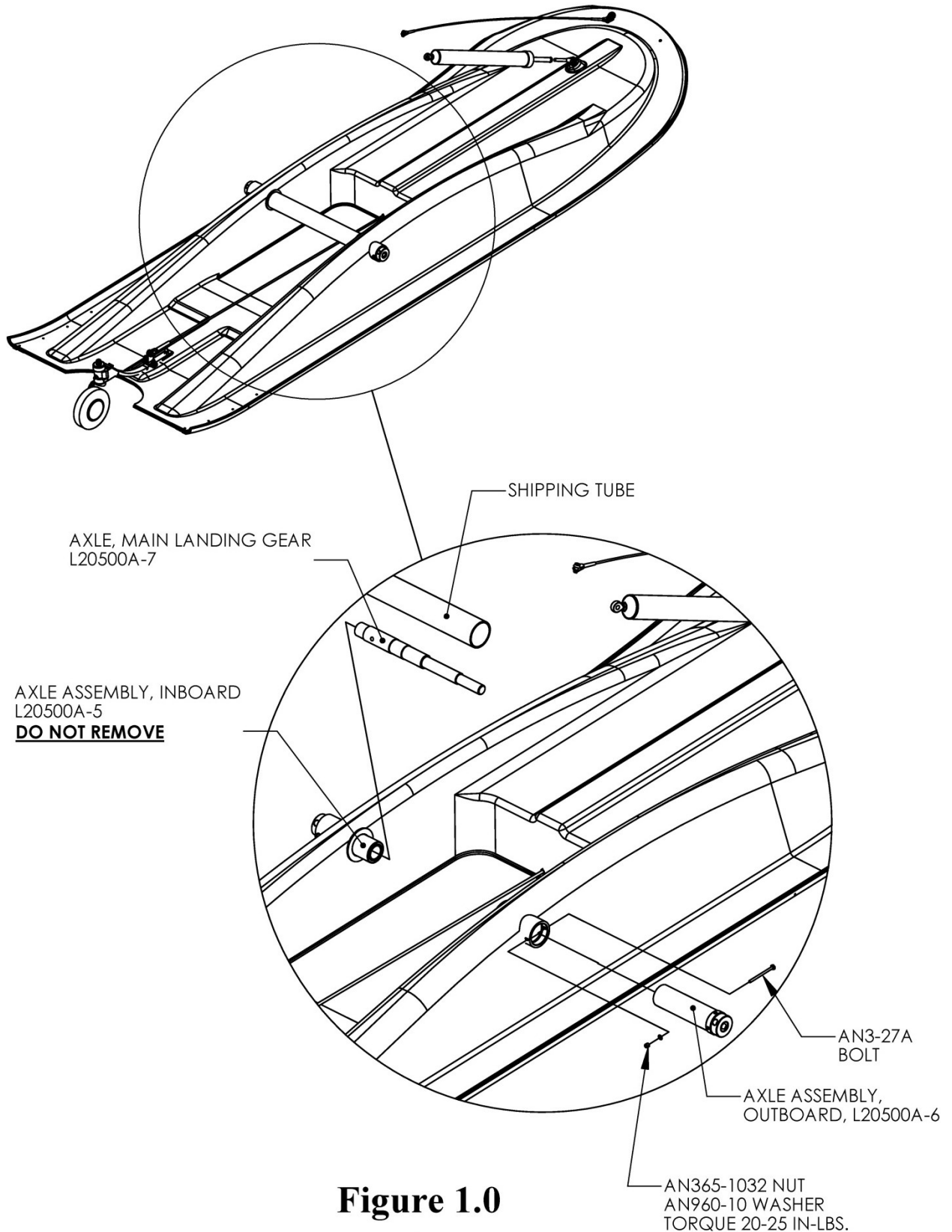

MAIN SKI – SKI PREPARATION FOR ASSEMBLING TO AH-64D

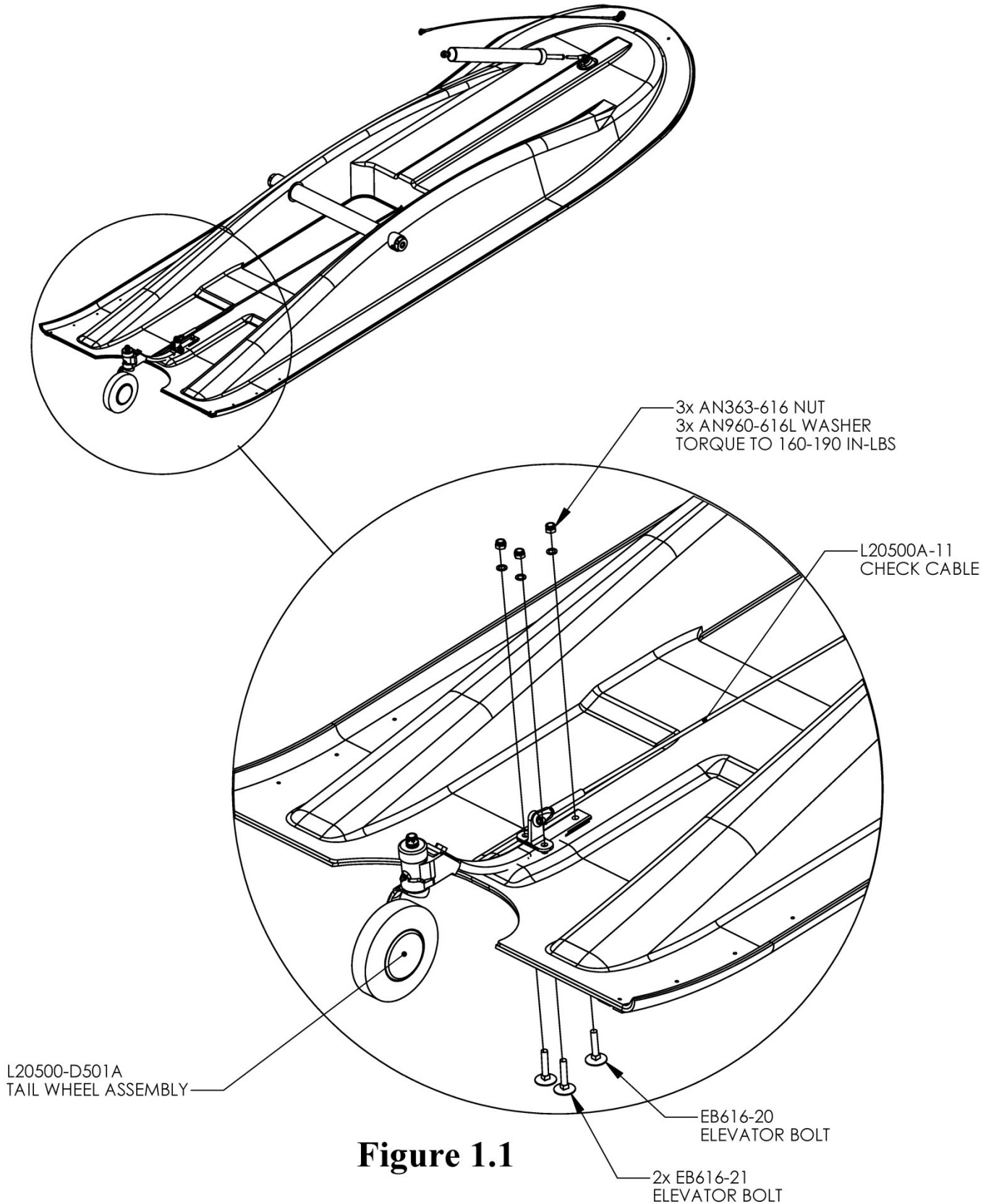

Figure 1.1

TAIL SKI – SKI PREPARATION FOR ASSEMBLING TO AH-64D

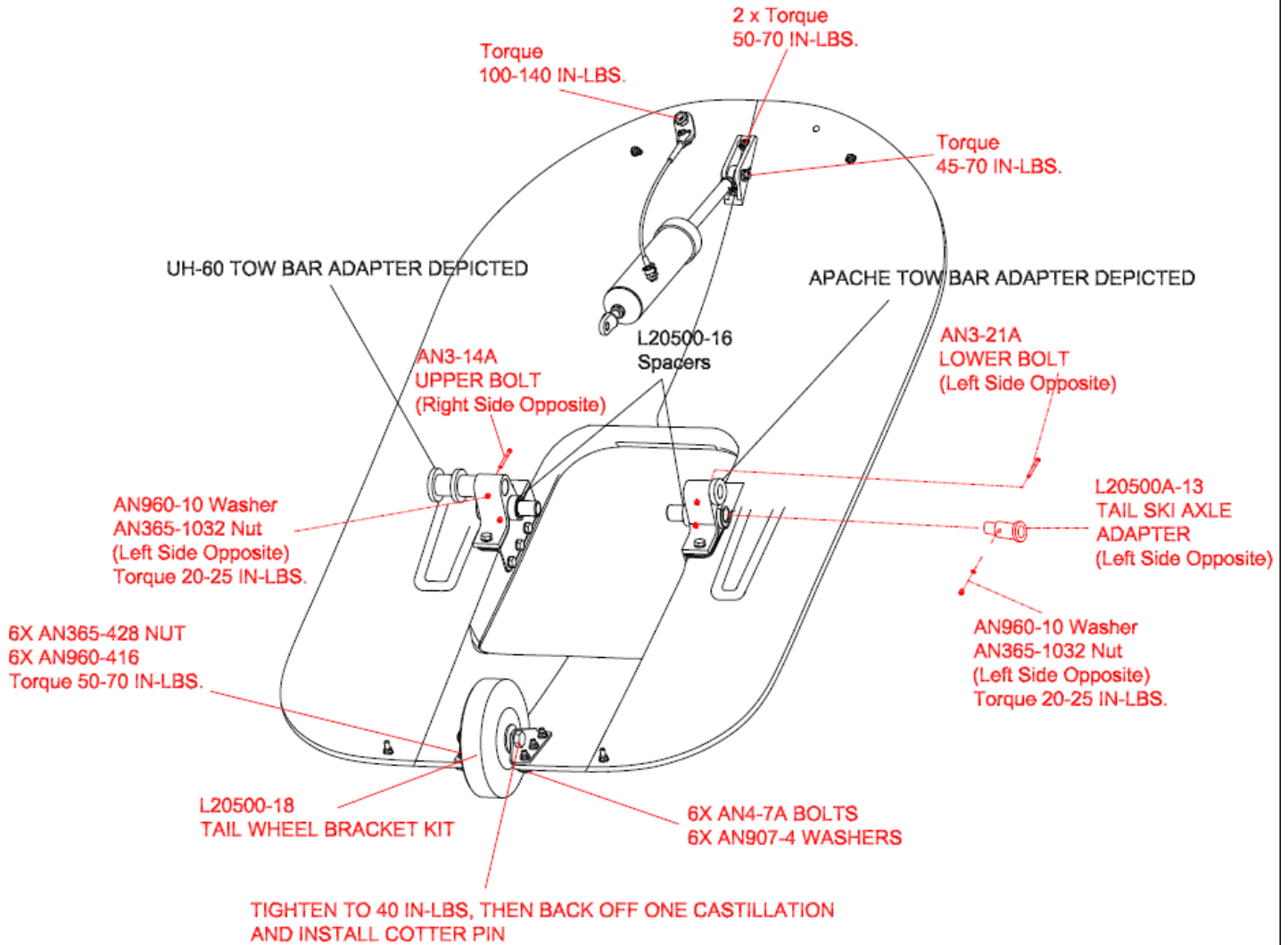

FIGURE 2.

MAIN GEAR – BOEING STEP AND PLATE REMOVAL

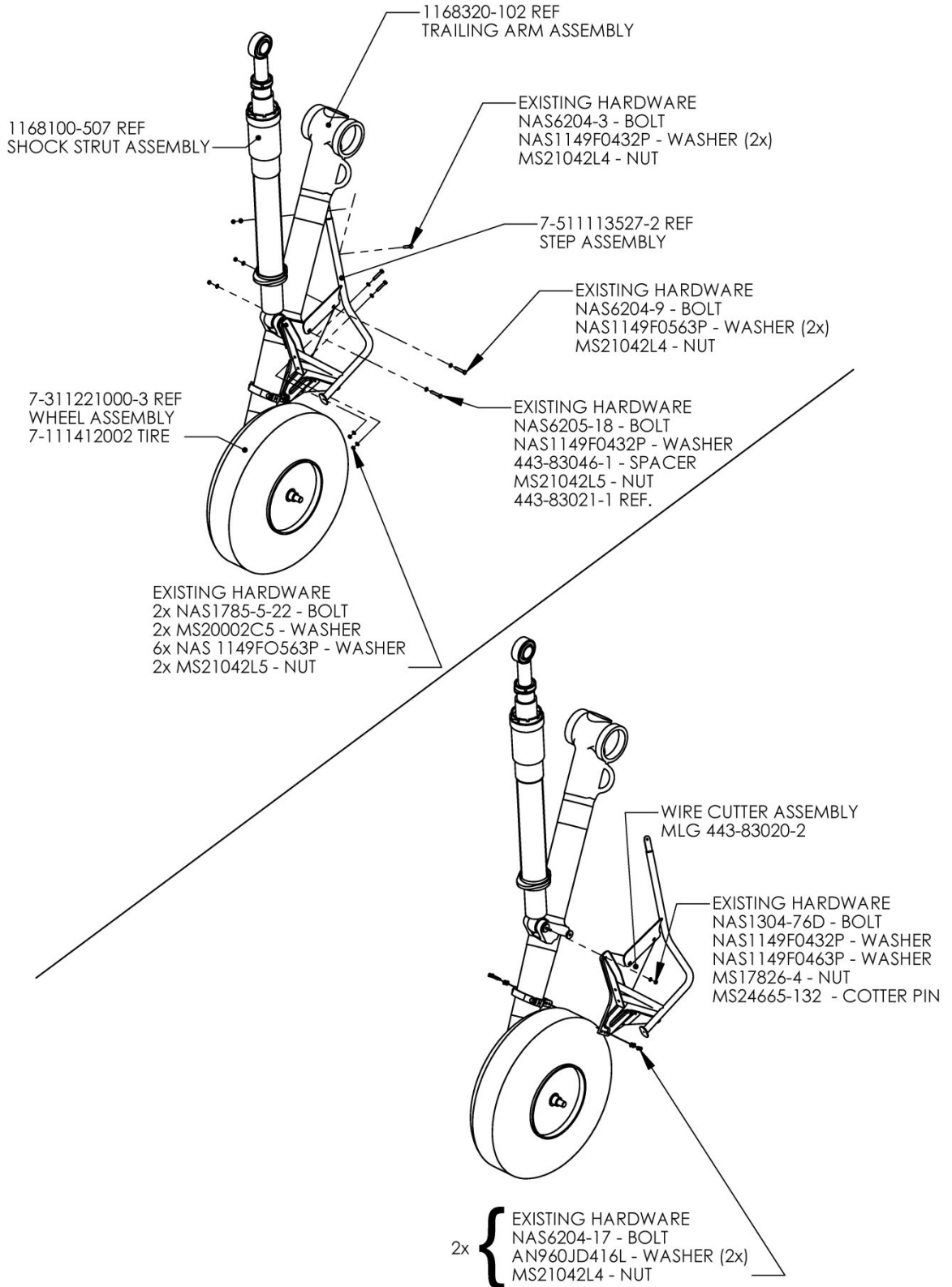

Figure 3.0

MAIN GEAR – AIRGLAS BRACKET AND STEP ASSEMBLY

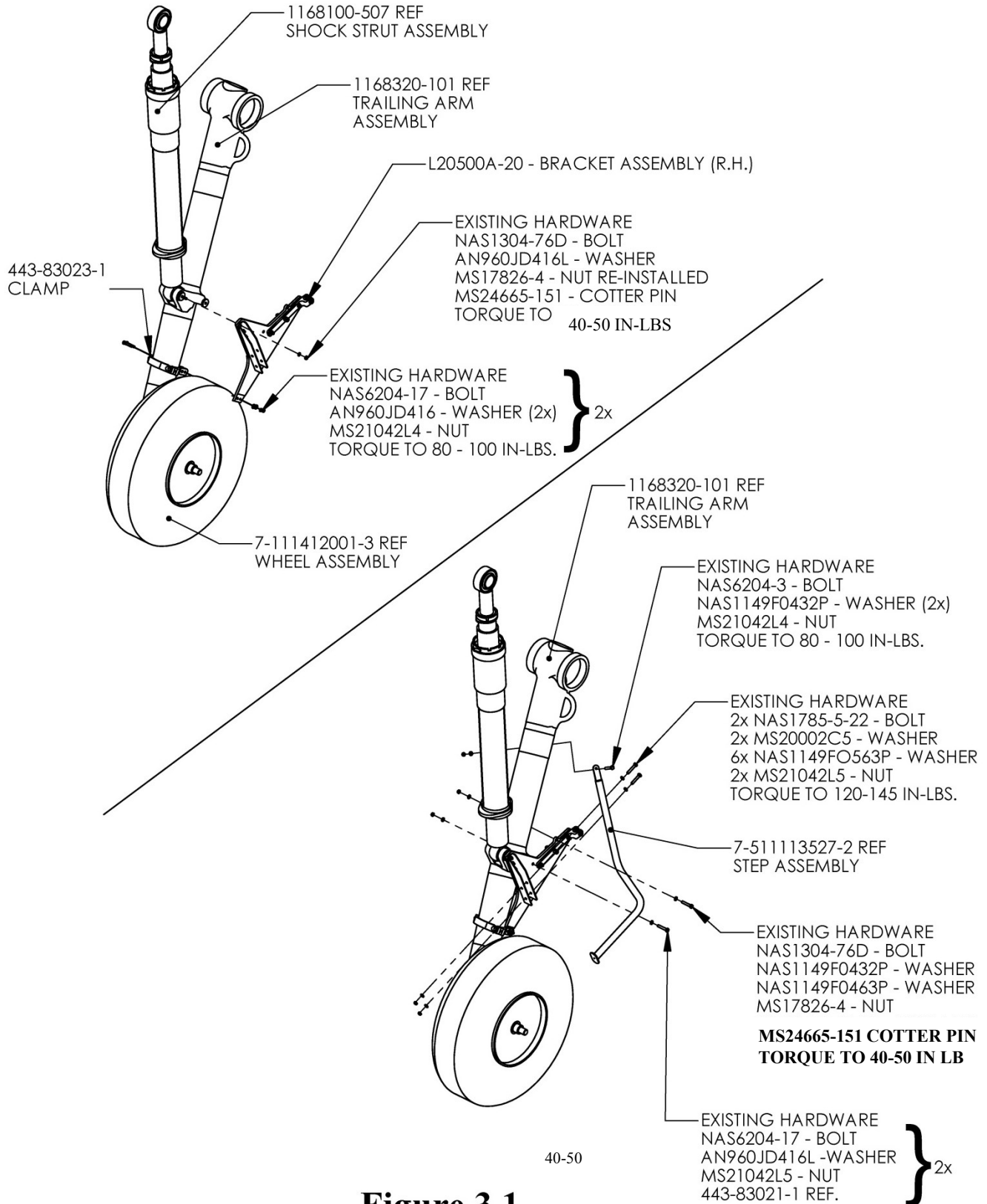

Figure 3.1

MAIN GEAR – JACK PAD REMOVAL / AXLE ASSEMBLY

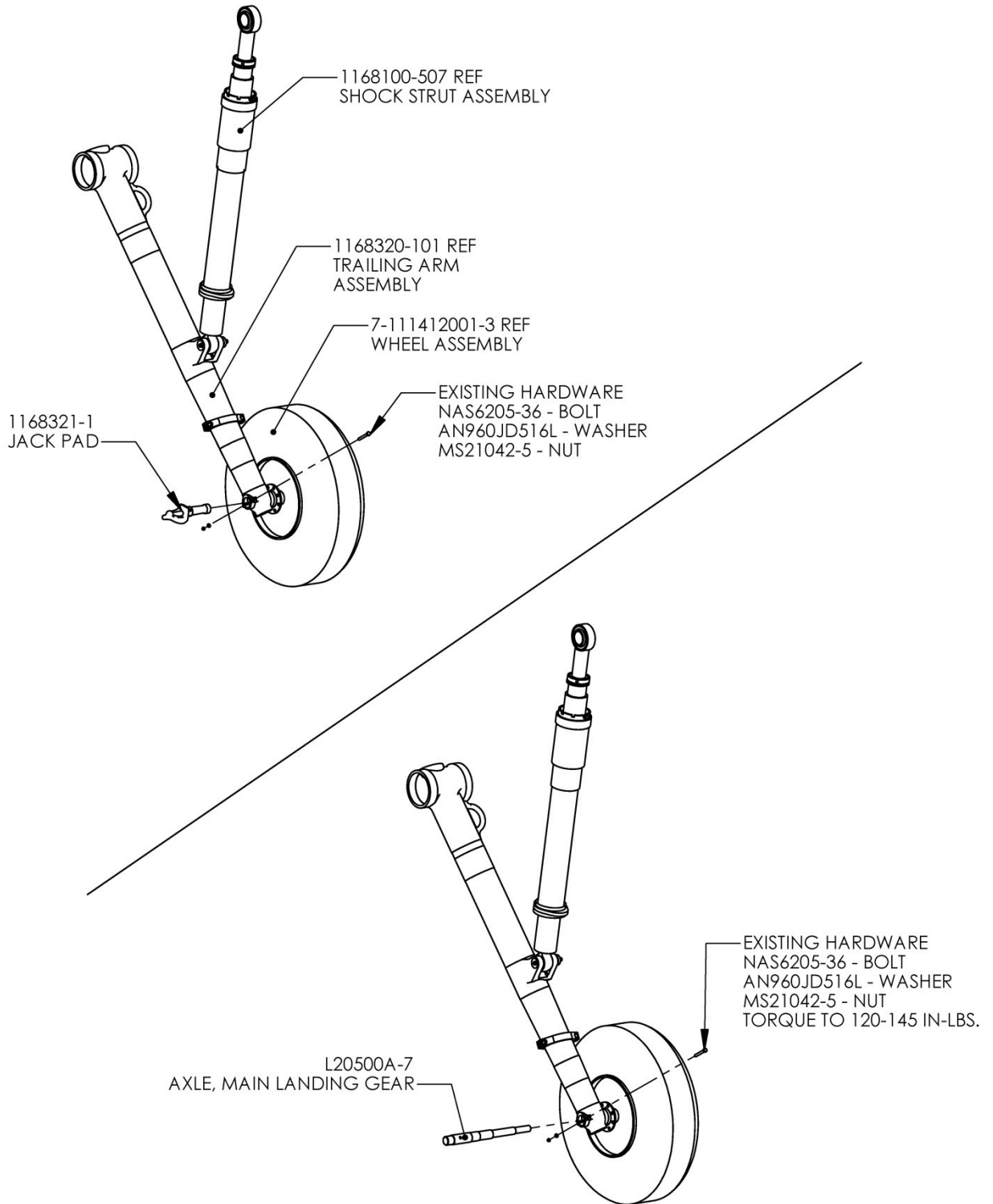

Figure 3.2

MAIN GEAR / TAIL GEAR – PRE-INSTALL SKI POSITION

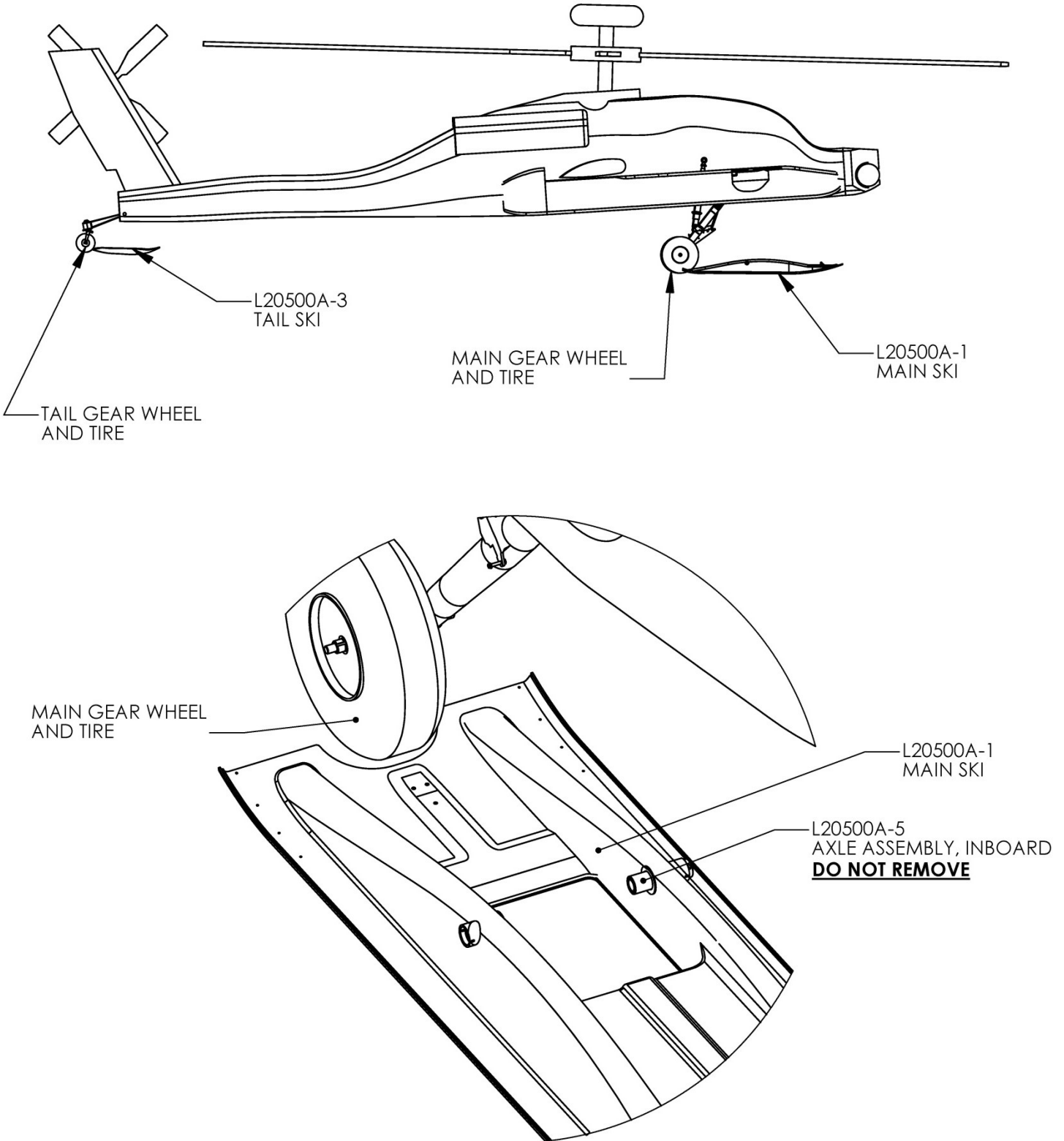

Figure 5.0

MAIN SKI – AXLE POSITIONING AND ASSEMBLY

MOVE SKI FORE OR AFT TO ALIGN
AXLE ASSEMBLY, INBOARD (L20500A-5)
WITH AXLE, MAIN LANDING GEAR (L20500A-7)

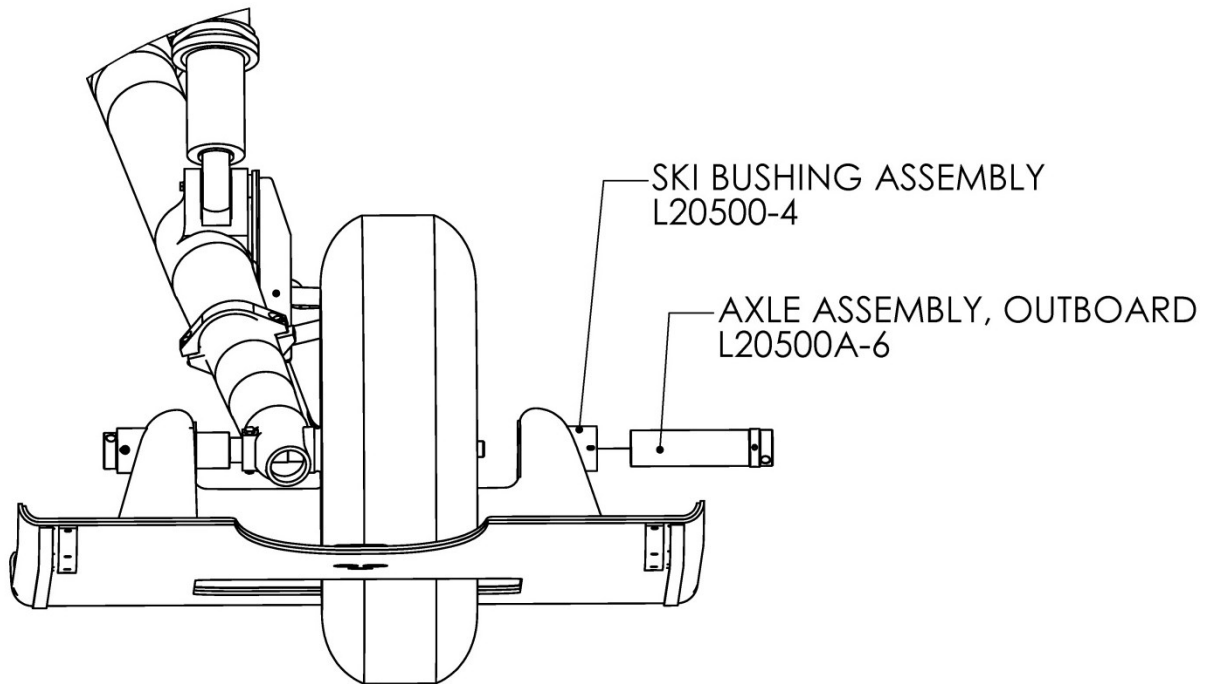
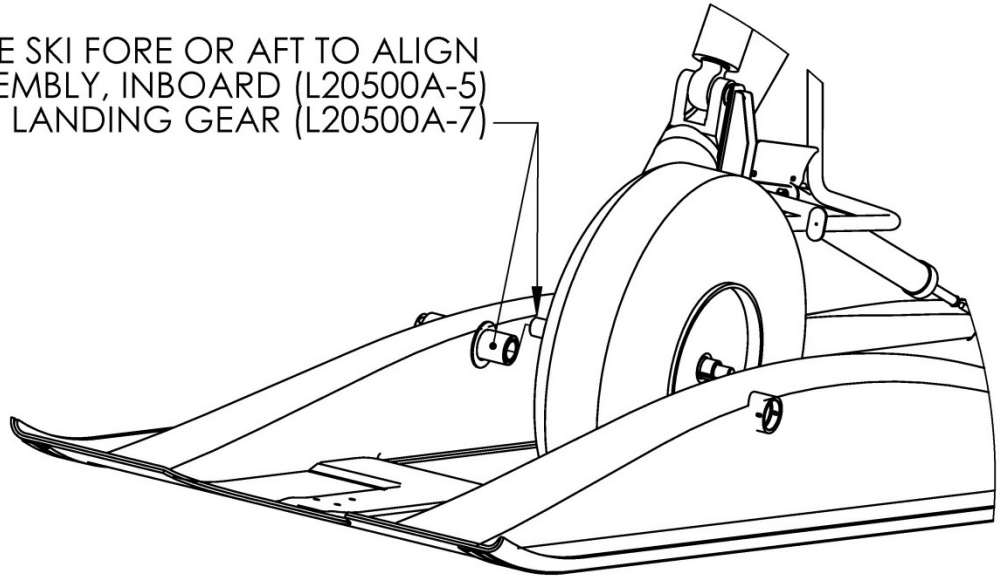

Figure 5.1