

REVISIONS				
ZONE	LTR	DESCRIPTION	DATE	APPROVED
	A	ADDED CLARIFICATION TO DRAWING	27 Sep 22	JDH

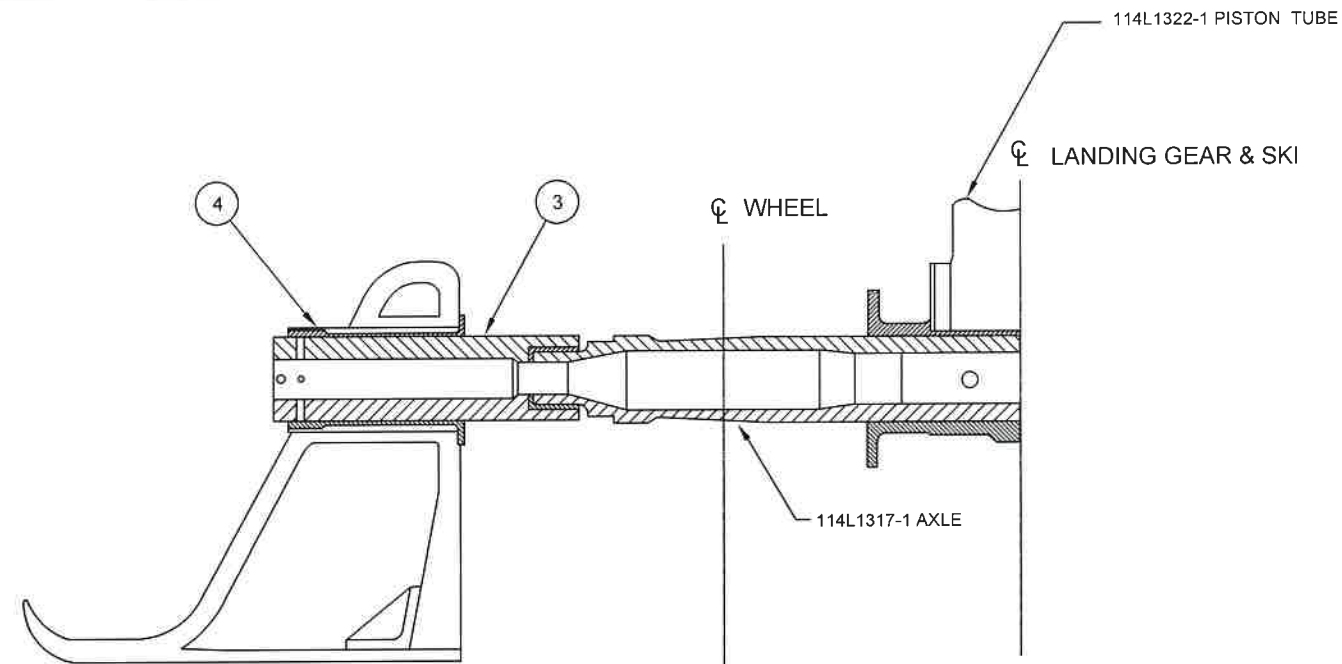

BL 63.00

SECTION B-B, 90 DEG HALF SCALE

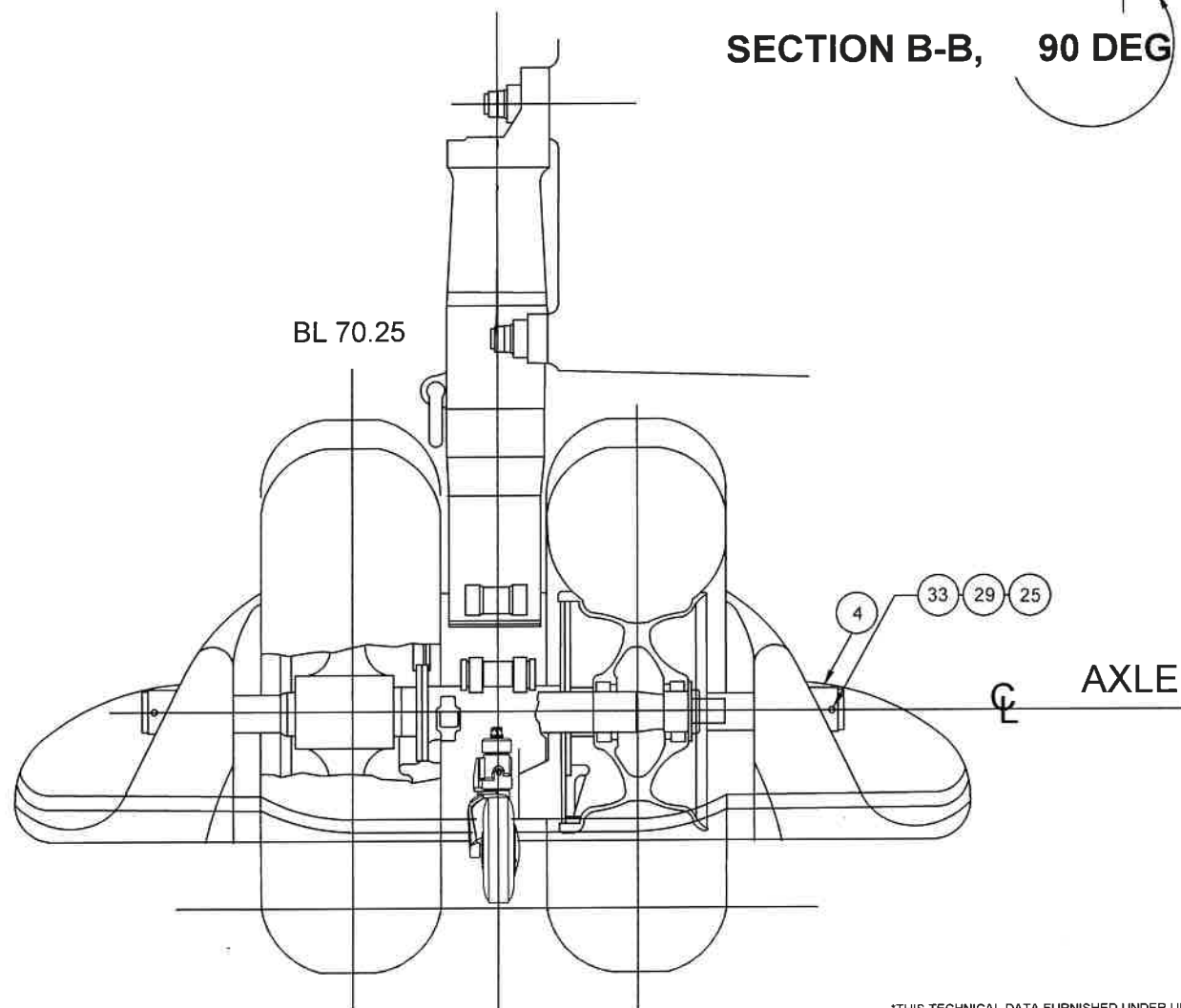

BL 70.25

END VIEW LOOKING FWD- FWD L.H. SKI

NOTE

1. SKI INTERCHANGABLE FROM LEFT TO RIGHT
2. TIGHTEN AXLES (ITEM NO. 3) UNTIL THERE IS NO CLEARANCE. BACK AXLES (ITEM NO. 3) OUT UNTIL AN3-27A BOLT CAN BE INSTALLED.
3. NO PLATING REQUIRED ON SKI AXLES (ITEM NO. 3) USED ON SKI SERIAL NO. 170 & ON, OR OTHER SKIS WITH P/N L44000-11-4 MADE OF AMPCO M-4 ALUMINUM BRONZE.

*THIS TECHNICAL DATA FURNISHED UNDER UNITED STATES GOVERNMENT CONTRACT NO. DAAJ01-71-C-0437 (P1F), SHALL NOT, WITHOUT THE WRITTEN PERMISSION OF AIRGLAS, INC. BE EITHER (a) USED, RELEASED IN WHOLE OR IN PART OUTSIDE THE GOVERNMENT. (b) USED IN WHOLE OR PART BY THE GOVERNMENT FOR MANUFACTURE OR (c) USED BY A PARTY OTHER THAN THE GOVERNMENT, EXCEPT FOR: (1) EMERGENCY REPAIR OR OVERHAUL WORK ONLY, OR FOR THE GOVERNMENT, WHERE THE ITEM OR PROCESS CONCERNED IS NOT OTHERWISE REASONABLY AVAILABLE TO ENABLE TIMELY PERFORMANCE OF THE WORK, PROVIDED THAT THE RELEASE OR DISCLOSURE HEREOF OUTSIDE THE GOVERNMENT, AS THE INTEREST OF THE UNITED STATES MAY REQUIRE, ONLY FOR INFORMATION OR EVALUATION WITHIN SUCH GOVERNMENT OR FOR EMERGENCY REPAIR OR OVERHAUL WORK OR FOR SUCH GOVERNMENT UNDER THE CONDITION OF ABOVE. THIS LEGEND SHALL BE MARKED ON ANY REPRODUCTION HEREOF IN WHOLE OR PART.

NO.	QTY.	CODE IDENT. NO.	PART NO.	DISCRIPTION	STOCK SIZE	MATL.	MATL. SPEC.	UTS 1000	FINISH	CALC. UNIT	ACT. WT	ZONE
35	1		AN380-2-2	COTTER PIN								
34	1		AN380-3-3	COTTER PIN								
33	2		AN3-27A	BOLT								
32	1		AN960-716	WASHER								
31	2		AN960-616L	WASHER								
30	1		AN960-516	WASHER								
29	4		AN960-10	WASHER								
28	1		AN365-720	NUT								
27	3		AN363C-616	NUT								
26	1		AN365-524	NUT								
25	3		AN365-1032	NUT								
24	1		AN320-6	NUT								
23	1		AN320-5	NUT								
22	1		AN47-14	EYE BOLT								
21	1		AN26-23	CLEVIS BOLT								
20	1		AN25-15	CLEVIS BOLT								
19	1		AN7-13A	BOLT								
18	3	17564	EB616-24	BOLT								
17			(RESERVED)									
16	1		AN5-7A	BOLT								
15	1		AN3-44A	BOLT								
14		17564	L20500-D501A-6 (modified)	LEAF SPRING								
13	1	17564	L20500-D501A-6	LEAF SPRING								
12	1	17564	L20500-D501A-5	LEAF SPRING								
11	1	17564	L44000-17	FWD SPRING CYL.								
10	2	17564	L44000-10	TAB								
9	1		A512	Spacer, Tailwheel Leaf Spring								
8	1	17564	L44000-11-8HD	SAFETY CABLE								
7	1	17564	L44000-11-7	CHECK CABLE								
6	2	17564	L44000-11-6	END FITTING								
5	1	17564	L44000-11-5	SWIVEL FITTING								
4	2	17564	L44000-11-4	AXLE BUSHING								
3	2	17564	L44000-11-3	SKI AXLE ASSY.								
2	1	17564	L44000-D501HD	TAILWHEEL ASSY								
1	1	17564	L44000-2	BASIC MOULDING								
1	1	17564	L44000-11	SKI ASSY FWD.								

LIST OF MATERIALS

UNLESS OTHERWISE SPECIFIED DIMENSIONS ARE IN INCHES TOLERANCES EXCEPT AS NOTED DECIMALS X ± .03 ANGLES XX ± .03 XX ± .005 X ± 5°		Airglas, Inc. Anchorage, Alaska	
HEAT TREAT MATL. GOV SPEC STEEL MIL-H-8875 ALUM MIL-H-8898 MAG CAST MIL-H-6887		Approved by: CB Checked by: CB Drawn by: JDH Date: OCT 02, 1965	
114L1010-5-7 NEXT ASSY USED ON APPLICATION		Size B Code Ident. No. 17564 L44000-11HD Scale DO NOT SCALE	
		Sheet 2 OF 2	