

REVISIONS				
ZONE	LTR	DESCRIPTION	DATE	APPROVED
	A	ADDED CLARIFICATION TO DRAWING	29 Sep 22	JDH

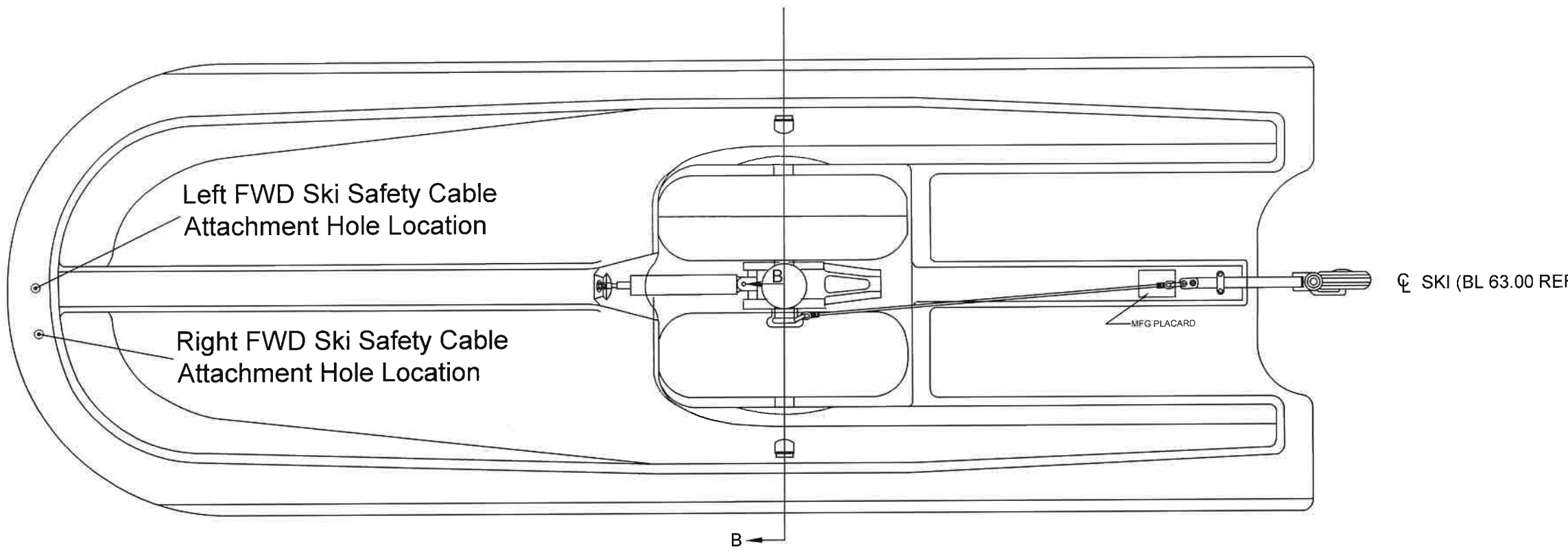

- NOTE**
1. SKI INTERCHANGABLE FROM LEFT TO RIGHT
 2. TIGHTEN AXLES (ITEM NO. 3) UNTIL THERE IS NO CLEARANCE. BACK AXLES (ITEM NO. 3) OUT UNTIL AN3-27A BOLT CAN BE INSTALLED.
 3. NO PLATING REQUIRED ON SKI AXLES (ITEM NO. 3) USED ON SKI SERIAL NO. 170 & ON, OR OTHER SKIS WITH P/N L44000-11-4 MADE OF AMPCO M-4 ALUMINUM BRONZE.

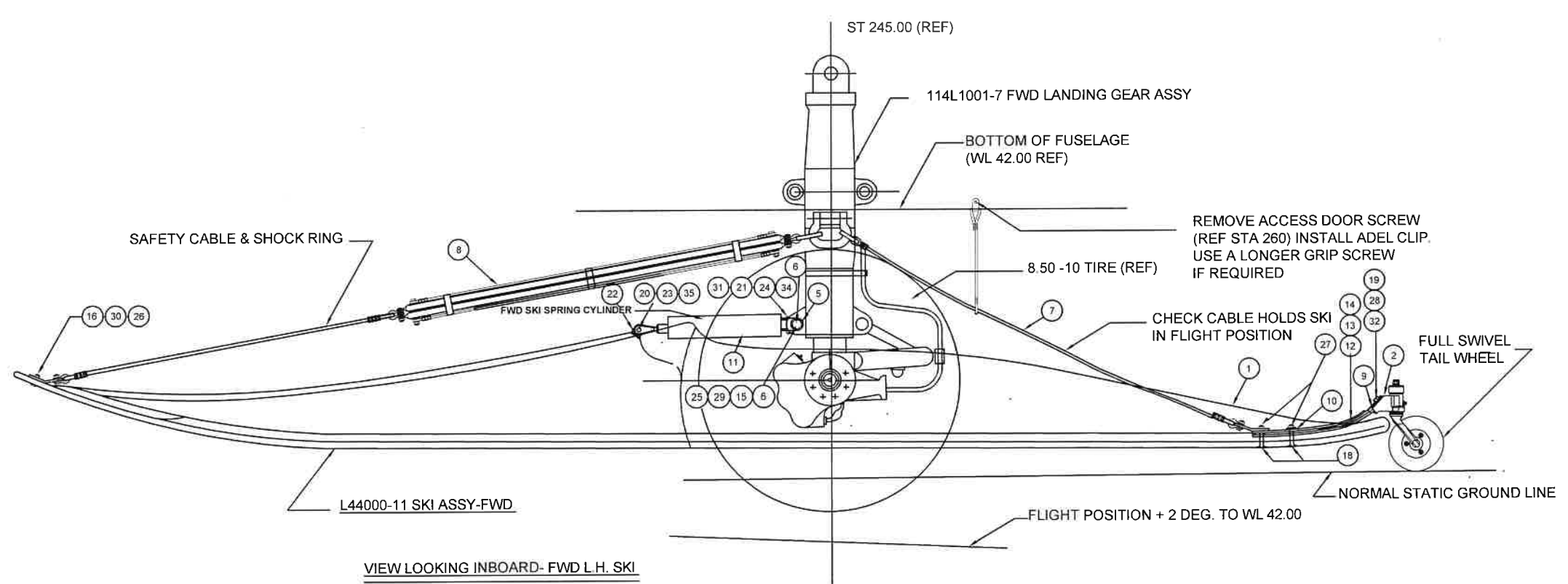

*THIS TECHNICAL DATA FURNISHED UNDER UNITED STATES GOVERNMENT CONTRACT NO. DAAJ01-71-C-0437 (P1P), SHALL NOT, WITHOUT THE WRITTEN PERMISSION OF AIRGLAS, INC. BE EITHER (a) USED, RELEASED IN WHOLE OR IN PART OUTSIDE THE GOVERNMENT, (b) USED IN WHOLE OR PART BY THE GOVERNMENT FOR MANUFACTURE OR (c) USED BY A PARTY OTHER THAN THE GOVERNMENT, EXCEPT FOR: (1) EMERGENCY REPAIR OR OVERHAUL WORK ONLY, OR FOR THE GOVERNMENT, WHERE THE ITEM OR PROCESS CONCERNED IS NOT OTHERWISE REASONABLY AVAILABLE TO ENABLE TIMELY PERFORMANCE OF THE WORK, PROVIDED THAT THE RELEASE OR DISCLOSURE HEREOF OUTSIDE THE GOVERNMENT, AS THE INTEREST OF THE UNITED STATES MAY REQUIRE, ONLY FOR INFORMATION OR EVALUATION WITHIN SUCH GOVERNMENT OR FOR EMERGENCY REPAIR OR OVERHAUL WORK OR FOR SUCH GOVERNMENT UNDER THE CONDITION OF ABOVE. THIS LEGEND SHALL BE MARKED ON ANY REPRODUCTION HEREOF IN WHOLE OR PART.

UNLESS OTHERWISE SPECIFIED DIMENSIONS ARE IN INCHES TOLERANCES EXCEPT AS NOTED		Airglas, Inc. Anchorage, Alaska	
HEAT TREAT		SKI ASSEMBLY, FORWARD HEAVY DUTY INST.	
MATL	GOV SPEC	Approved by : CB	Size B
STEEL	MIL-H-6875	Checked by : CB	Code Ident No. 17564
ALUM	MIL-H-6086	Drawn by : JDH	L44000-11HD
MAG CAST	MIL-H-6357	Date : 14 May 2014	REV A
APPLICATION		Scale	Sheet 1 OF 2