

REVISIONS				
ZONE	LTR	DESCRIPTION	DATE	APPROVED
	A	ADD PARTS LIST	08 OCT 1965	WKL
	B	REMOVED PARTS 9 13 14 FROM L/M REMOVED PART 30512-04 FROM 12 & MADE IT PART 13 L/M REMOVED DETAILS -9, -10 ADDED REF CALLOUT FOR AXLE & PISTON TUBE PER PTM 8-4432- S-1071 UPDATED DWG PER BOEING LETTER 8-4432-2-8091 SEPT 5, 1970	20 APR 1968	WKL
	C	ADD NOTE NO. 3 & L44000-D501A	22 AUG 1965	WKL
	D	ELECTRONIC DWG CREATED PART NUMBERS CHANGED	23 AUG 2011	CED
	E	Added Cotter Pin Callouts To Drawing (ITEM 34 & 35)	24 SEP 2014	CB
	F	Added/Changed Part Numbers	28 AUG 2017	CB

NOTE

1. SKI INTERCHANGABLE FROM LEFT TO RIGHT
2. TIGHTEN AXLES (ITEM NO. 3) UNTIL THERE IS NO CLEARANCE. BACK AXLES (ITEM NO. 3) OUT UNTIL AN3-27A BOLT CAN BE INSTALLED.
3. NO PLATING REQUIRED ON SKI AXLES (ITEM NO. 3) USED ON SKI SERIAL NO. 170 & ON, OR OTHER SKIS WITH P/N L44000-11-4 MADE OF AMPCO M-4 ALUMINUM BRONZE.

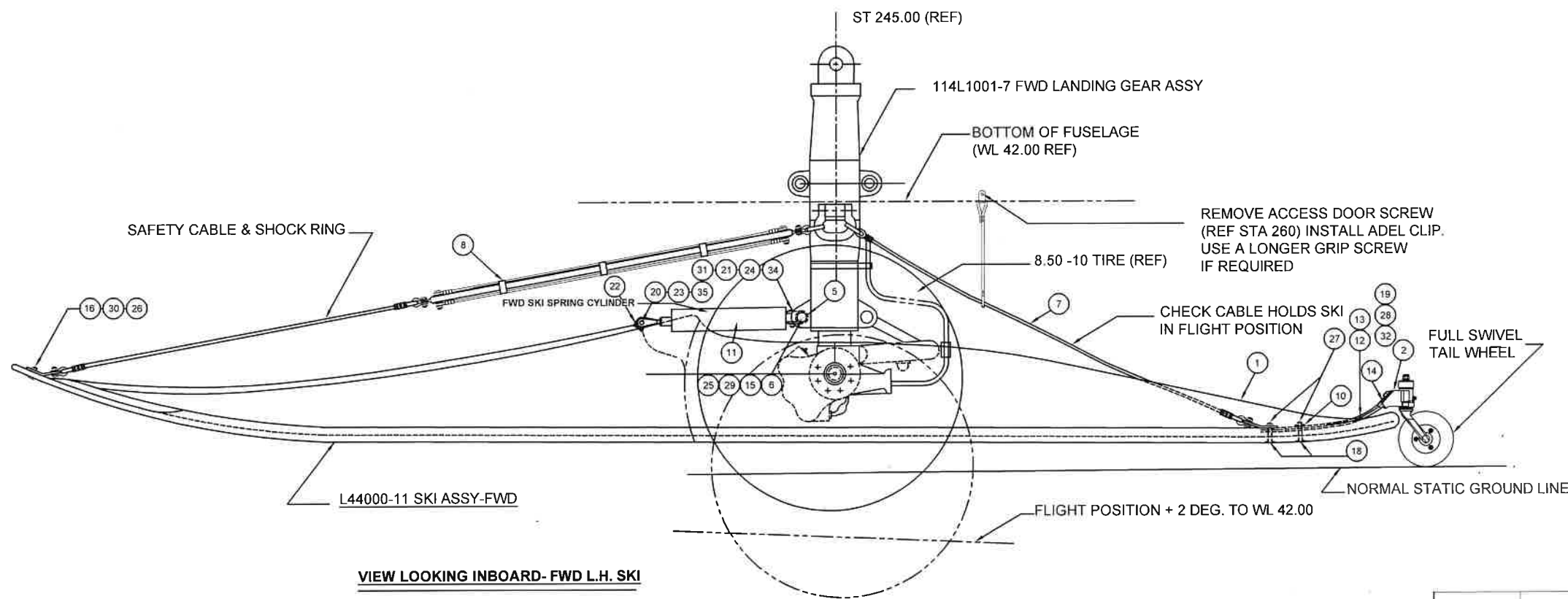
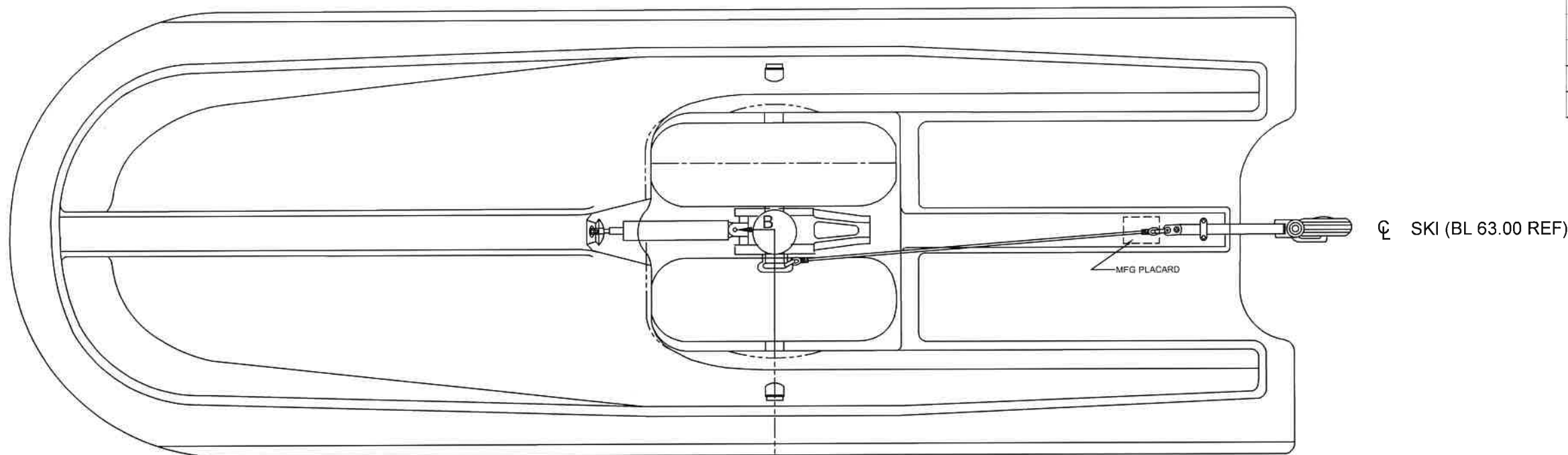

\*THIS TECHNICAL DATA FURNISHED UNDER UNITED STATES GOVERNMENT CONTRACT NO. DAAJ01-71-C-0437 (P1F), SHALL NOT, WITHOUT THE WRITTEN PERMISSION OF AIRGLAS, INC. BE EITHER (a) USED, RELEASED IN WHOLE OR IN PART OUTSIDE THE GOVERNMENT. (b) USED IN WHOLE OR PART BY THE GOVERNMENT FOR MANUFACTURE OR (c) USED BY A PARTY OTHER THAN THE GOVERNMENT, EXCEPT FOR: (1) EMERGENCY REPAIR OR OVERHAUL WORK ONLY, OR FOR THE GOVERNMENT, WHERE THE ITEM OR PROCESS CONCERNED IS NOT OTHERWISE REASONABLY AVAILABLE TO ENABLE TIMELY PERFORMANCE OF THE WORK, PROVIDED THAT THE RELEASE OR DISCLOSURE HEREOF OUTSIDE THE GOVERNMENT, AS THE INTEREST OF THE UNITED STATES MAY REQUIRE, ONLY FOR INFORMATION OR EVALUATION WITHIN SUCH GOVERNMENT OR FOR EMERGENCY REPAIR OR OVERHAUL WORK OR FOR SUCH GOVERNMENT UNDER THE CONDITION OF ABOVE. THIS LEGEND SHALL BE MARKED ON ANY REPRODUCTION HEREOF IN WHOLE OR PART.

UNLESS OTHERWISE SPECIFIED DIMENSIONS ARE IN INCHES TOLERANCES EXCEPT AS NOTED DECIMALS X ± 1 ANGLES XX ± 03 XXX ± 005 X ± 5'		Airglas, Inc. Anchorage, Alaska	
HEAT TREAT MATERIAL GOV SPEC STEEL MIL-H-6875 ALUM MIL-H-6098 MAG CAST MIL-H-6887		Approved by: WKL	SKI ASSEMBLY FORWARD INSTL. OF
114L1010-5-7 NEXT ASSY	CH-47A.B.C USED ON	Checked by:	Size B Code Ident No. 17564
APPLICATION		Drawn by: PS	L44000-11
		Date: OCT 02, 1965	REV F
		Scale: DO NOT SCALE	Sheet 1 OF 2