

# L44000-11/13 REPAIR APPENDIX

Airglas, Inc. created this repair guidance to assist repair technicians in evaluating and repairing the L44000 skis, used on the CH-47 skis.

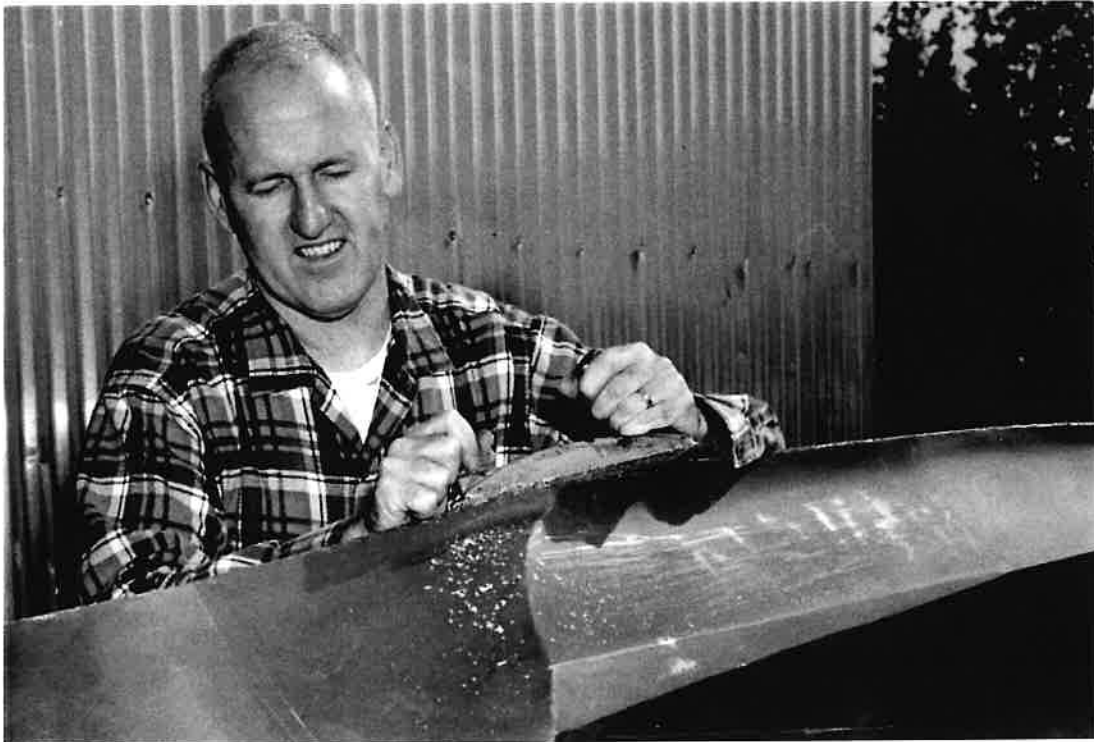

**WES LANDES (FOUNDER OF AIRGLAS, INC. )**

**L44000 Ski Repair Limits Manual**  
DATE: 18 December 2012

# L44000-11 (CH-47 FWD SKI)

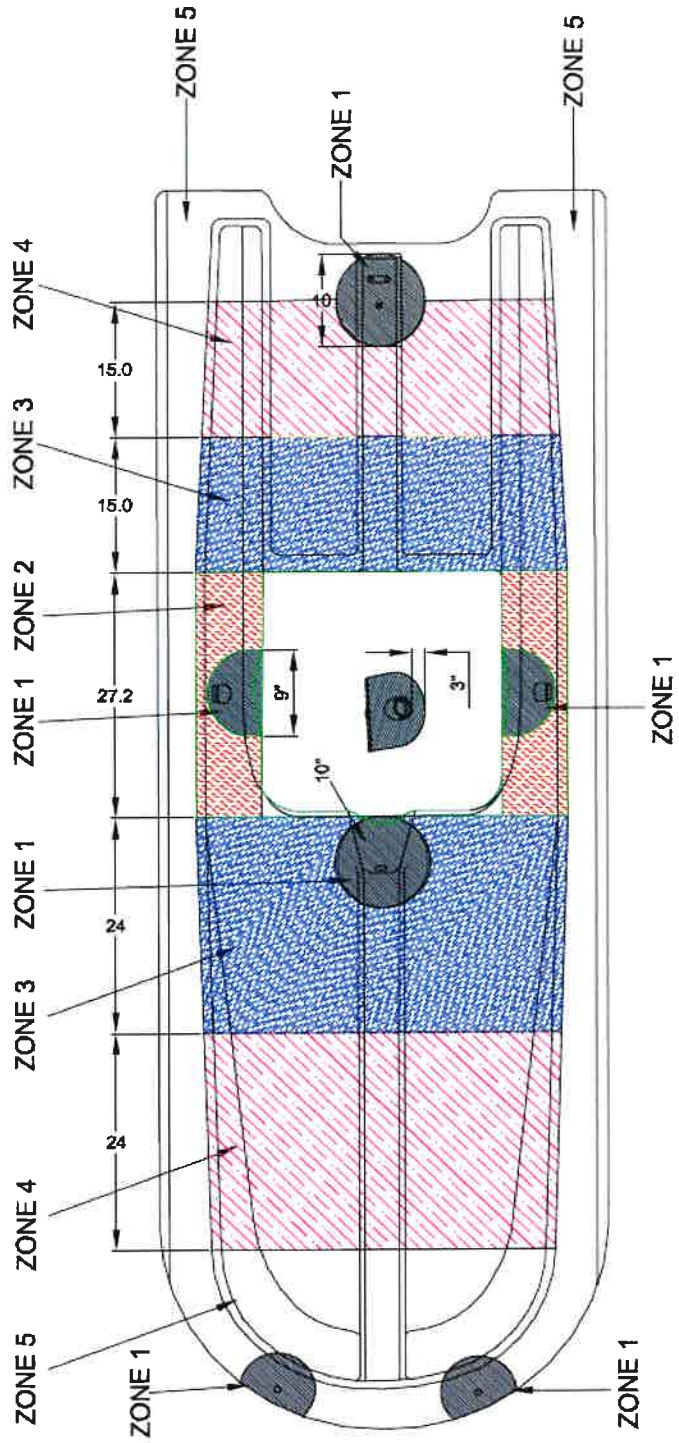

# L44000-11 SKI BOTTOM DAMAGE LIMITS

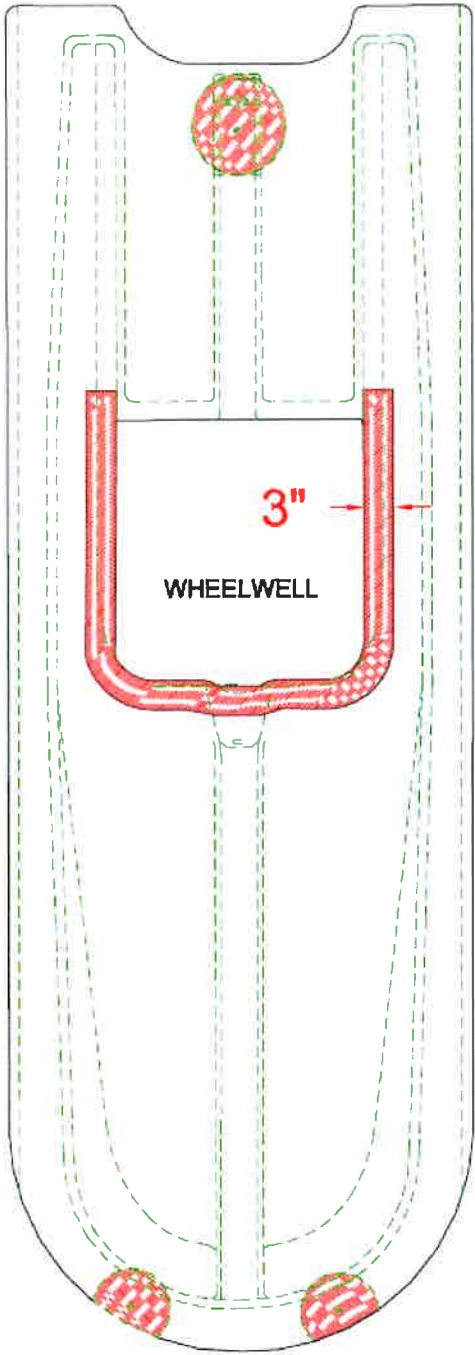

# L44000-13 (CH-47 AFT SKI)

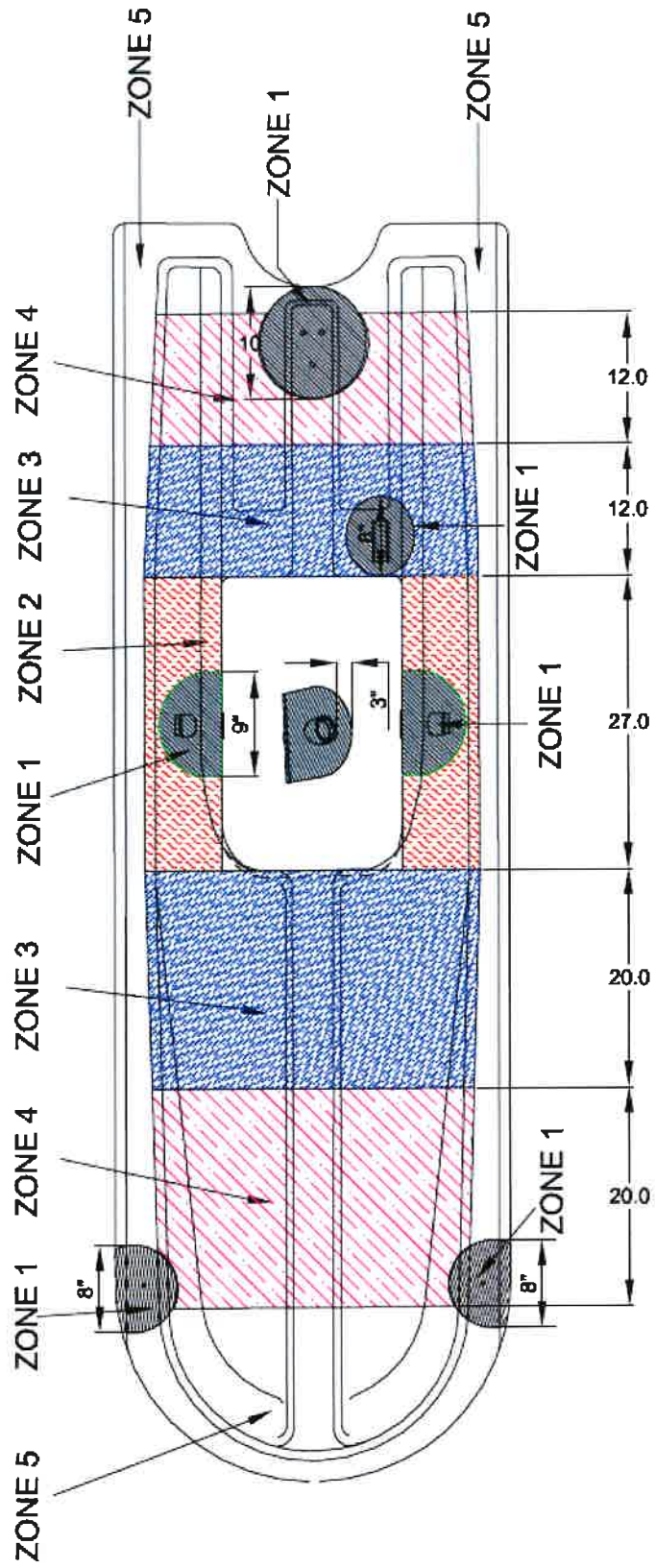

---

# L44000-13 SKI BOTTOM DAMAGE LIMITS

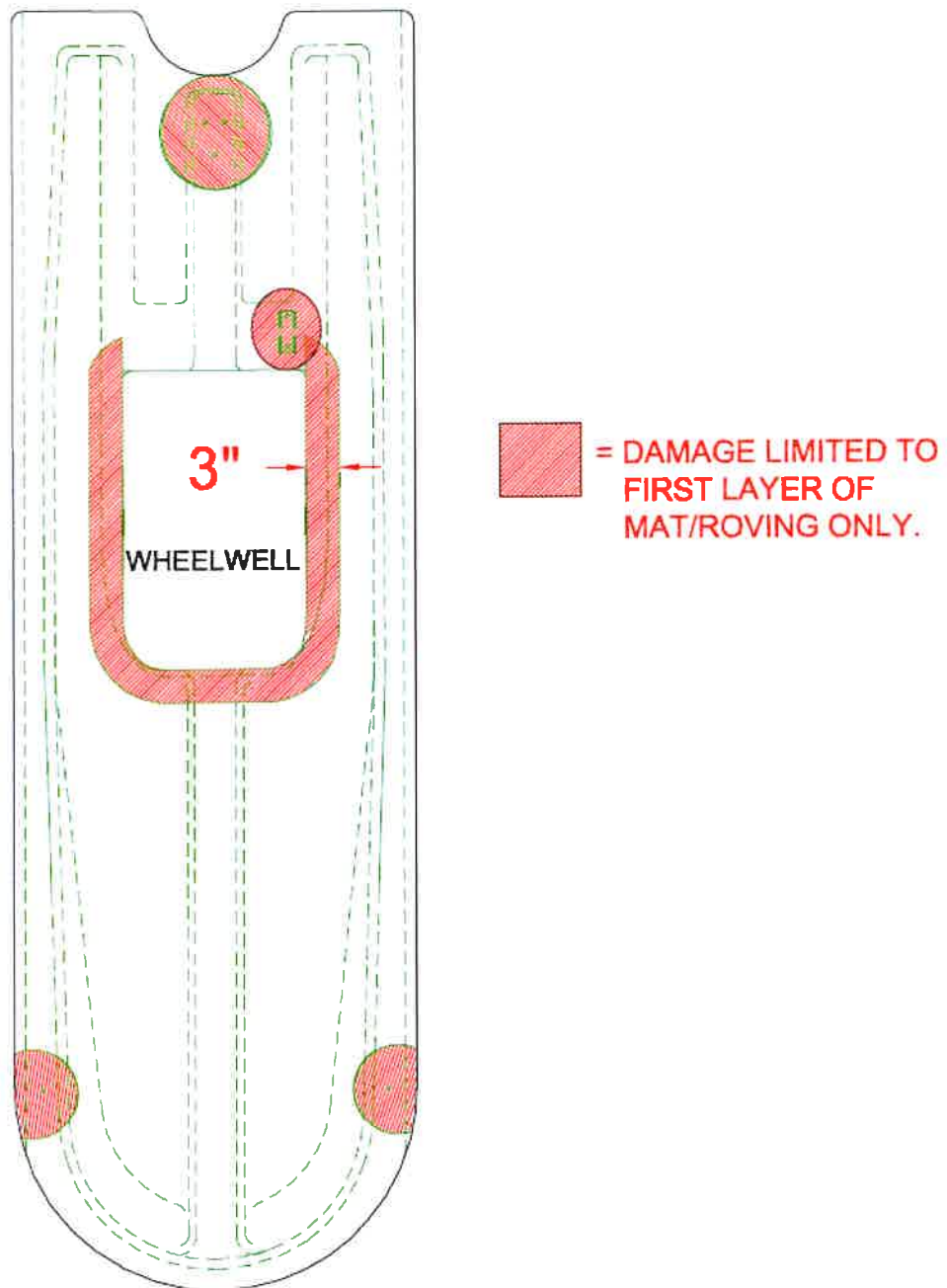

## L44000-11 & 13 SKI ZONE REPAIR LIMITS

### Zone 1-

**Zone 1 areas are critical stress areas.** These areas include the area immediately surrounding bushing, and attachment areas for cables and spring cylinders. This mandates that the repairs to these areas are extremely limited. (See drawing for clarification.)

**Repair:** None, unless approved by Airglas, Inc.

Note: Airglas will typically only approve repairs involving replacement of ski bushings. In order for Airglas to give approval to replace bushings, unit must have training and an appropriate fixture for aligning bushings.

### ZONE 2-

**Zone 2 areas are highly stressed areas.** Repairs to this area are very limited. This area includes the tunnel section of the ski, adjacent to wheel well. (See drawing for clarification.)

**Repair Limitation:** Repairs depths are limited to one layer of mat/roving only, involving less than 25% of the area of each tunnel vertical & horizontal cross section in this zone. See drawing for detail. The scarf method is to be used. See scarf method repair instructions.

### ZONE 3-

**Zone 3 areas are stressed areas.** Repairs to these areas are limited. This area includes the tunnel section of the ski, forward and aft of wheel well. (See drawing for clarification.)

**Repair Limitation:** Repairs depths are limited to the first two layers of mat/roving, involving less than 25% of each tunnel vertical & horizontal cross section for this zone. See drawing for detail. The scarf method is to be used. See scarf method repair instructions.

### ZONE 4-

**Zone 4 areas are less stressed areas.** Repairs to these areas are less limited. This area includes the tunnel section of the ski, forward and aft of wheel well. (See drawing for clarification.)

**Repair Limitation:** Repairs are limited to the first two layers of mat/roving, involving less than 40% of each tunnel vertical & horizontal cross section.

See drawing for detail. The scarf method is to be used. See scarf method repair instructions.

## **ZONE 5-**

**Zone 5 areas are lightly stressed areas.** Repairs to these areas are less limited. This area includes the perimeter of the ski. (See drawing for clarification.)

**Repair Limitation:** Repairs can affect both bottom and top of ski. **In which all layers of mat/roving are affected. Limit repairs to less than 30% of this area. Individual damaged areas are limited to 6" in length or width.**

**Individual repairs should be separated by at least:**

**12" for when it involves all fiberglass layers, both top & bottom plys.**

**8" when it only involves all plys on either top or bottom, but not both.**

**6" when it only involves limited plys of both top and bottom, in the same location.**

**3" between for all other repairs.**

**Note:** The purpose of this limit is to ensure adequate strength at the perimeter of the ski, after repairs.

See drawing for detail. The scarf method is to be used. See scarf method repair instructions

**NOTE: BOTTOM DAMAGE IN SHADED AREAS IS LIMITED TO ONE LAYER OF MAT ROVING. BOTTOM REPAIRS OUTSIDE SHADED AREAS ARE TREATED AS ZONE 5 REPAIR AREAS.**

**MAXIMUM REPAIR LIMIT DETERMINATION EXAMPLE:**

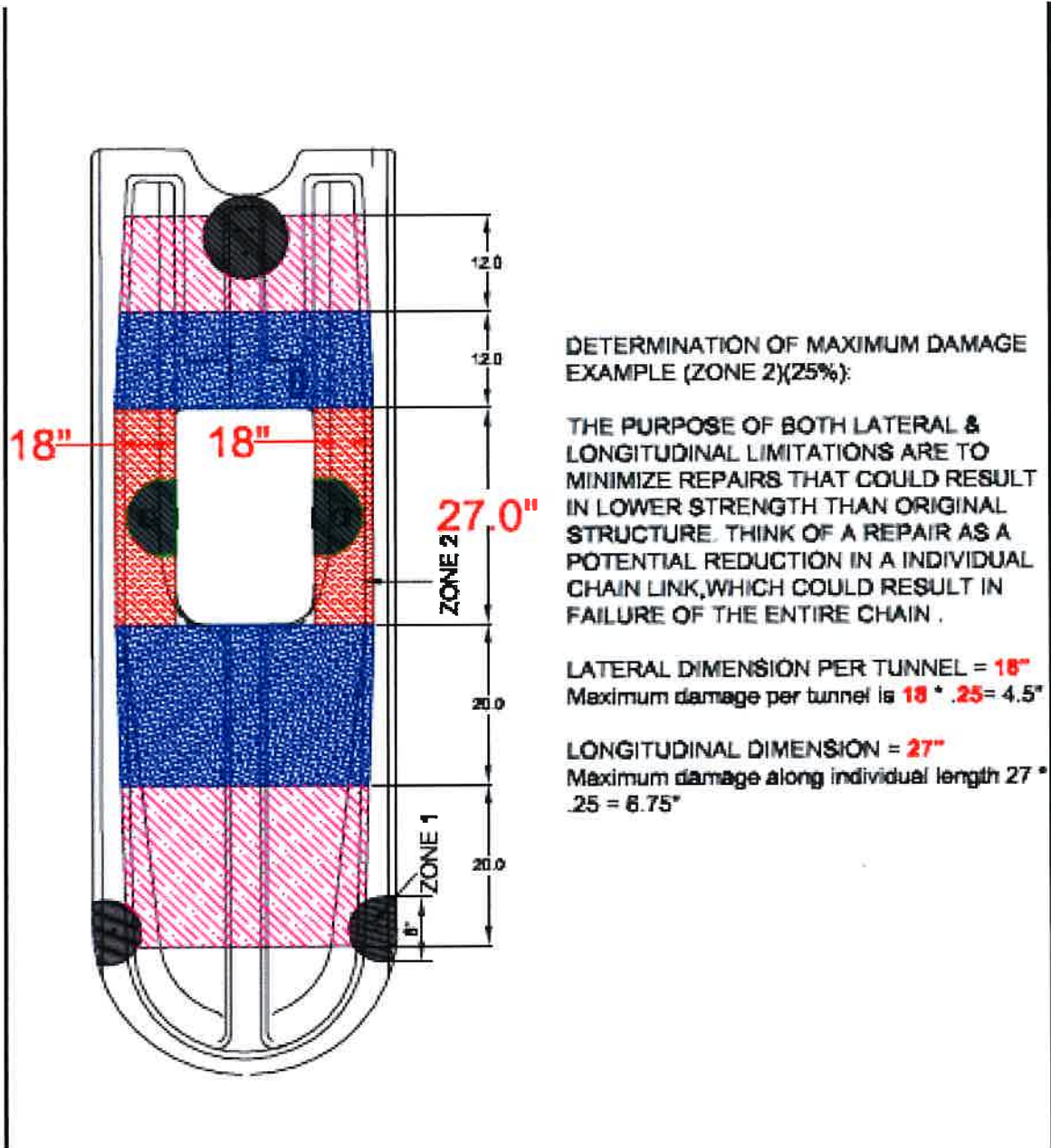

**DETERMINATION OF MAXIMUM DAMAGE EXAMPLE (ZONE 2)(25%):**

THE PURPOSE OF BOTH LATERAL & LONGITUDINAL LIMITATIONS ARE TO MINIMIZE REPAIRS THAT COULD RESULT IN LOWER STRENGTH THAN ORIGINAL STRUCTURE. THINK OF A REPAIR AS A POTENTIAL REDUCTION IN A INDIVIDUAL CHAIN LINK, WHICH COULD RESULT IN FAILURE OF THE ENTIRE CHAIN .

**LATERAL DIMENSION PER TUNNEL = 18"**  
Maximum damage per tunnel is  $18 \times .25 = 4.5"$

**LONGITUDINAL DIMENSION = 27"**  
Maximum damage along individual length  $27 \times .25 = 6.75"$



## **Bottom Abrasion Repair**

**If the bottom surface sustains excessive wear;** it may be sanded down with a 36 grit belt or disc sander and then recoated with epoxy or abrasion resistant gel coat. Once the epoxy or abrasion resistant gel coat is cured, the surface should be re-sanded with 80 grit paper using an orbiting sander.

1. Remove the hardware in the area of abrasion from the ski. If only a chip in bottom coating, without any hardware in area, complete steps 2-6 & 12-13.
2. Inspect ski for damage to fiberglass material on bottom. The bottom typically has a layer of heavy mat that is applied over the structural roving's. Abrasions only affecting the heavy mat are negligible. Make repairs to the ski as necessary when abrasive affects the roving. See repair limit criteria for damage to bottom repairs, when damage affects the roving's.
3. Clean surface of affected area with Acetone, prior to sanding surface. Sanding and grinding can cause contaminants to be driven further down into the ski fiberglass fibers.
4. Sand abraded area with a 36 grit sander. Use care to prevent grinding into roving's.
5. Apply bottom coating using brush, roller, and spray. Allow area to completely dry.

**Note: Epoxy and abrasion resistant gel coat formulas change over time. Older models used an epoxy based coat, which had black colorant mixed in. Newer skis bottoms use a special blend of black high abrasion gel-coat. Contact: *Airglas, Inc.* for current information on how to get needed material.**

6. Once bottom coat is dry, lightly scuff sand it with 80 grit sandpaper.
7. Position hardware in the same location as it came from step 1.
8. Apply SKI SWIFT PAINT (23T3-90/K1G), using precautions used for standard polyurethane coatings. ALLOW TO DRY FOR 24 HOURS.
9. Inspect your work for any defects and return ski to service.

### **Edge Laminate Repair**

1. Completely clean separated area with MEK, or Acetone. If possible, use thin blade to open separation to allow for a thorough cleaning of area.
2. Apply resin to separated area, attempt to force resin into separation. Apply a separator material (PVA, Teflon cloth, Nylon, etc.) to over affected area.
3. Use light clamping pressure to close separation area. Consider using open cell foam and large area pressure plate to disperse the pressure. Avoid using excessive clamping force, because it will squeeze out all resin. Do an immediate clean up of resin in the area.
4. Allow the resin to cure completely. Remove any resin that has spilled onto unaffected surfaces. Touch-up area needed with top coat. Airglas recommends that you use flat black "Krylon Fusion", because it adheres very well to the fiberglass resins. It's available at most hardware suppliers.

**NOTE:** For internal types of separations, contact Airglas, Inc. for possible solutions.

### **SCARF METHOD REPAIRS TO L44000-11&13 Skis**

1. Inspect area and determine that probable length. Note: It may be necessary to sand area of damage to exactly determine severity of damage (Length & Depth)
2. Remove any runner or hardware in area of crack.
3. Clean area of crack with Acetone, prior to sanding. This reduces the chances of embedding oils and grease into fibers in the unaffected areas.
4. Sand area of crack using a rotary sander with a 50-80 grit sander. Use a 12 to 1 ratio for removing crack (Example: If damage is .100" deep x .100 length, then the minimum radius would be 1.2"). The sanding area is typically circular, or oval. The radius is also affected by the size of damage. If length of the damage is 1" long, then the minimum radius would be  $(1" \div 2) + 1.2" = 1.7"$  radius. Remove damage in repair area up to limit.

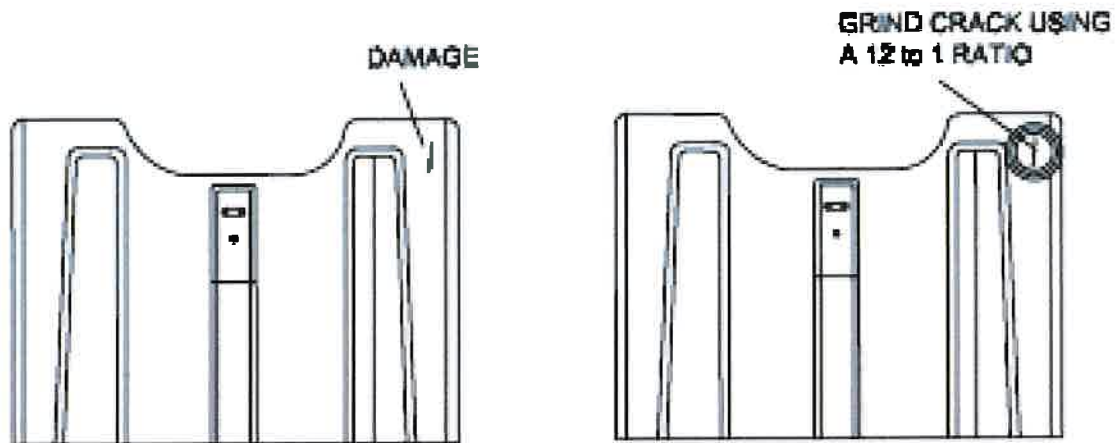

5. After all damage has been removed, determine the size of repair pieces needed. The first layer should be .5" larger than the smallest radius of the removed area. Airglas uses a mat/roving combination for all layers. Cut both mat/roving layers the same size.
6. Do a final clean of repair area.
7. Apply first layer of mat & roving. Wet out with resin, then roll using fiberglass roller. The fiberglass roller assists in breaking down fiber to accept resin. It also forces excess resin to the surface.
8. Apply second layer of mat & roving. Roll out material completely, before applying more resin. This prevents applying too much resin to glass in repair.

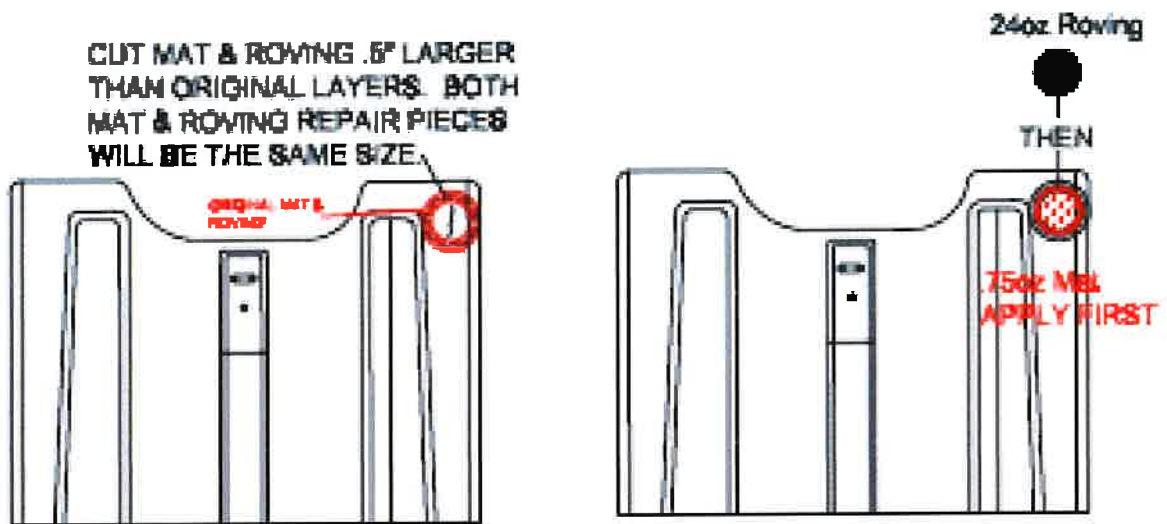

9. Apply final layer of mat & roving to repair area. Roll out material completely, before applying more resin. Wet out as needed.
10. Add final mat to top of repair to provide material to allow for a smoother surface finish when cured.
11. Allow repair to completely cure. When cured sand area to smooth the repair.

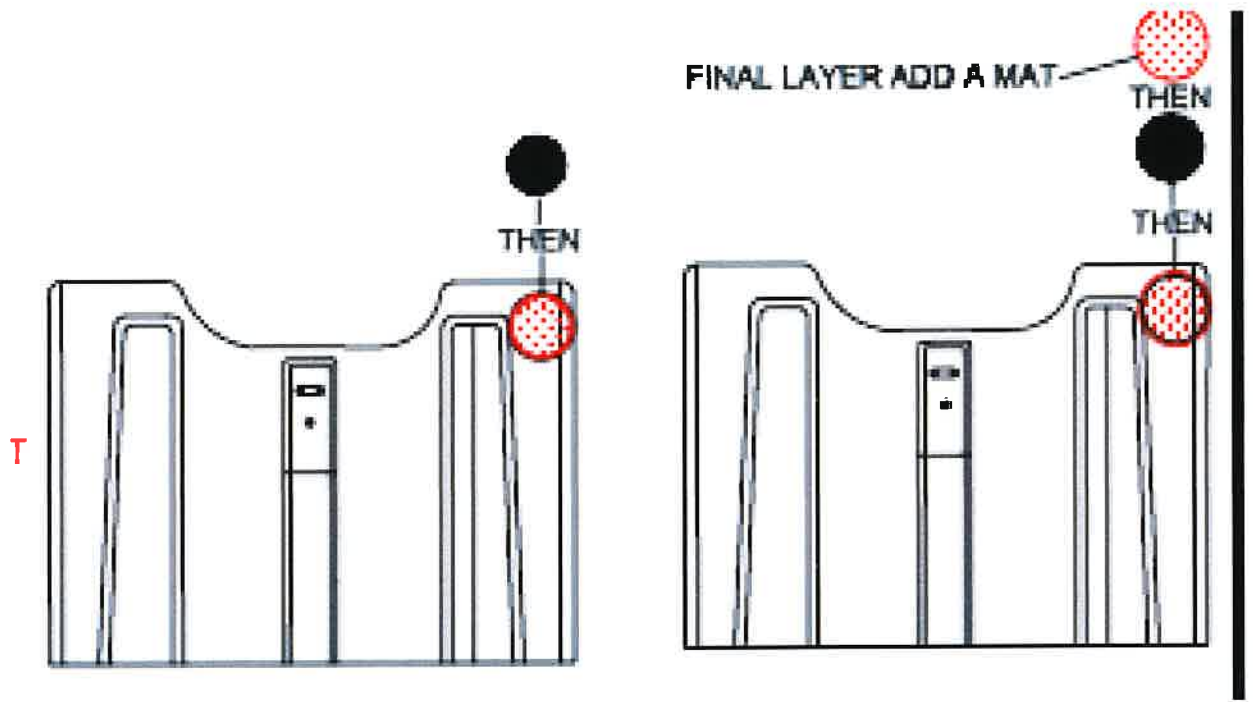

NOTE: AIRGLAS uses A .75oz. Mat and a 24oz Roving for every layer of the layup. For repair materials contact Airglas, Inc. to purchase a repair kit.

## ELEVATOR BOLT REPAIR PROCEDURE

### STEP 1 LOOSE ATTACH BOLT REPAIR

REMOVE TAIL WHEEL AND ALL ATTACH HARDWARE. ELEVATOR BOLTS ARE REMOVED BY TAPPING OUT WITH A RUBBER MALLET. IF AN ELEVATOR BOLT IS DIFFICULT TO REMOVE, THEN THIS REPAIR PROCEDURE IS NOT LIKELY NEEDED AT THAT LOCATION.

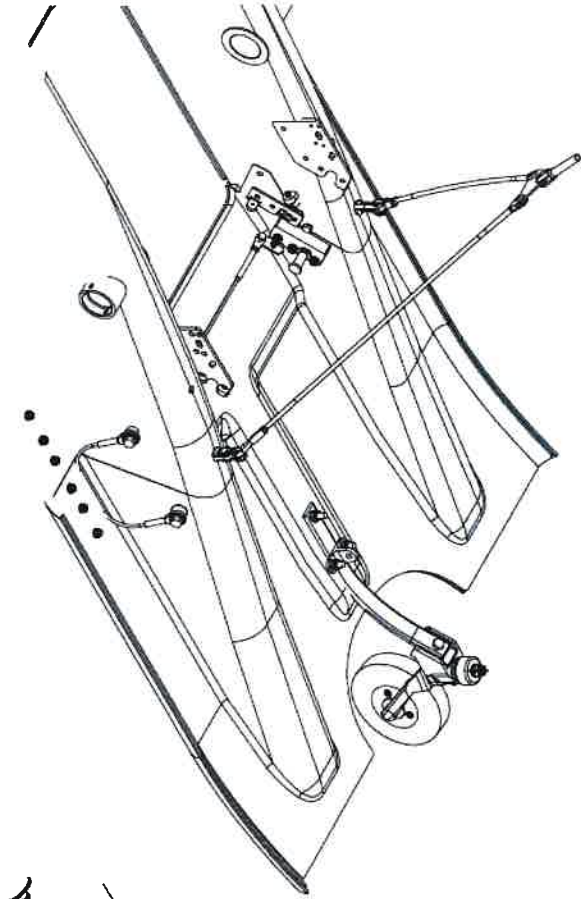

## **STEP 2 LOOSE ATTACH BOLT REPAIR**

**DO A COMPLETE CLEANING OF AREA OF HOLES,  
USING ACETONE OR A SUITABLE SUBSTITUTION.**

**WAX AREA AROUND HOLES. THIS WILL  
PREVENT RESIN FROM STICKING TO SKI  
DURING REPAIR. BE CAREFUL NOT TO GET WAX  
INSIDE HOLES.**

**MASK OFF AREAS OF ALL HOLES, BOTH TOP &  
BOTTOM.**

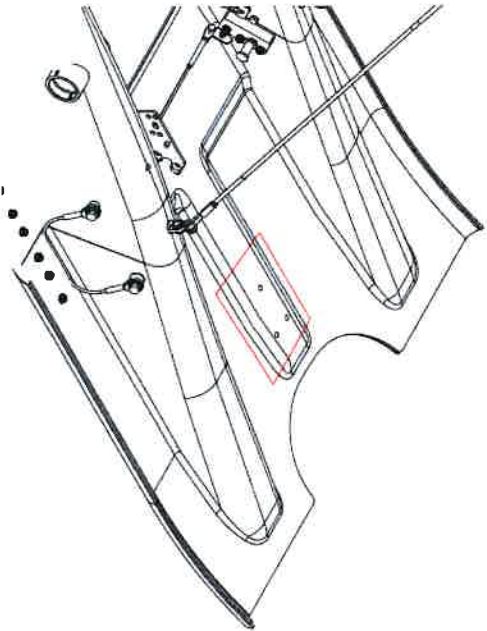

### STEP 3 LOOSE ATTACH BOLT REPAIR

CREATE A WET SLURRY OF RESIN (VINYL ESTER OR POLYURETHANE) AND 1/8 MILL FIBER. ALTERNATE IS TO USE MAT CUT INTO VERY SMALL PIECES. THE MIXTURE SHOULD BE BETWEEN 70-80%. USE A 2% MEKP TO RESIN RATIO (RESIN SHOULD BE PRE-PROMOTED WITH COBALTY) CHECK WITH THE RESIN MANUFACTURE FOR MORE INFO ON WHETHER ITS PRE-PROMOTED. NOTE: MOST COMMERCIAL GRADE RESINS ARE PRE-PROMOTED.

NOTE: ANY 1/8 MILL FIBER OR CHOPPED STRAND MAT FIBER CAN BE USED. THE PURPOSE OF THE MAT IS TO REINFORCE THE RESIN. THE RESIN TYPE IS THE IMPORTANT MATERIAL.

DOUBLE WAX (PASTE WAX) THE ELEVATOR BOLTS, TO PREVENT RESIN FROM STICKING TO BOLT AFTER CURE. ALLOW WAX TO DRY, AND WIPE OFF DRIED RESIDUE.

APPLY RESIN SLURRY INTO HOLE. INSERT THE ELEVATOR BOLTS. COMPLETELY INTO HOLE (ENSURE BOLT IS FLUSH ON BOTTOM OF SKI). THE RESIN AND SLURRY WILL FORM TO THE SQUARE PORTIONS OF THE ELEVATOR BOLT, PREVENTING THE BOLT FROM TURNING AFTER COMPLETE CURE. THE BOLTS WILL NOT NEED TO BE REMOVED.

CLEAN UP ALL EXCESS RESIN WITH ACETONE OR SUITABLE SUBSTITUTION.

ALLOW RESIN TO CURE COMPLETELY. TYPICAL CURE TIME AT ROOM TEMPERATURE IS 24 HOURS.

