



Date: 8 March 2018

PRE-2014 LH3600-5 YOKE SERVICE BULLETIN

REASON:

Airglas has received 4 reports of the LH4000 yoke (PN LH3600-5) of the welds shearing off the outboard arm of the yoke. The common thread between all occurrences is a heavy side load is applied to the skis. This sideways load appears to happen in a turn. In three cases, pilot reported to Airglas that they hit an obstruction in a turn.

The yokes Airglas manufactured up until 2014 were manufactured differently than current yoke. The older yokes were welded and then post heat-treated, followed by a mag-particle inspection. We have also seen some evidence that yokes may have been partially cracked, prior to final heavy side load occurrence. The yokes are powder coated, and this may be masking partial cracks.

DESCRIPTION

This service document provides instructions to inspect the Pre-2014 LH3600-5 yokes.

COMPLIANCE

MANDATORY: This service document must be accomplished at the next 50-hours.

NOTE: After the initial inspection, this service letter inspection must be completed every 50 hours.

A service document published by Airglas Inc. may be recorded as *completed* in an aircraft log only when the following requirements are satisfied:

- 1) The mechanic must complete all of the instructions in the service document, including the intent therein.
- 2) The mechanic must correctly use and install all applicable parts supplied with the service document kit. Only with written authorization from Airglas can substitute parts or rebuilt parts be used to replace new parts.
- 3) The mechanic or airplane owner must use the technical data in the service document only as approved and published.
- 4) The mechanic or airplane owner must use maintenance practices that are identified as acceptable standard practices in the aviation industry and governmental regulations.



No individual or corporate organization other than Airglas Inc. is authorized to make or apply any changes to a Airglas-issued service document or flight manual supplement without prior written consent from Airglas.

5) Airglas is not responsible for the quality of maintenance performed to comply with this document.





SKI YOKE REMOVAL

1. Prior to ski removal, disconnect all rigging, the aircraft can be hoisted or jacked to remove all rigging. We recommend removing rear check cable and forward safety cable first. Then aircraft can be hoisted or jacked to remove bungee cable. Rotating the ski down will relieve tension on the bungee for easier removal.
2. With ski supported, remove the two each NAS1312-15 bolts on each ski that go thru the CM-12 rod ends on yoke, see item 63 in figure 1.
3. Once rigging and NAS1312-15 bolts are removed, ski will be free of aircraft.
4. The next step is to remove the yokes from the skis. To do this (See Figure 1) remove axle rod nut (item 26). This will allow you to remove the axle rod (item 22), followed by the removal of the two buckets ((Item 21). The yoke will be free of the ski.

FIGURE 1

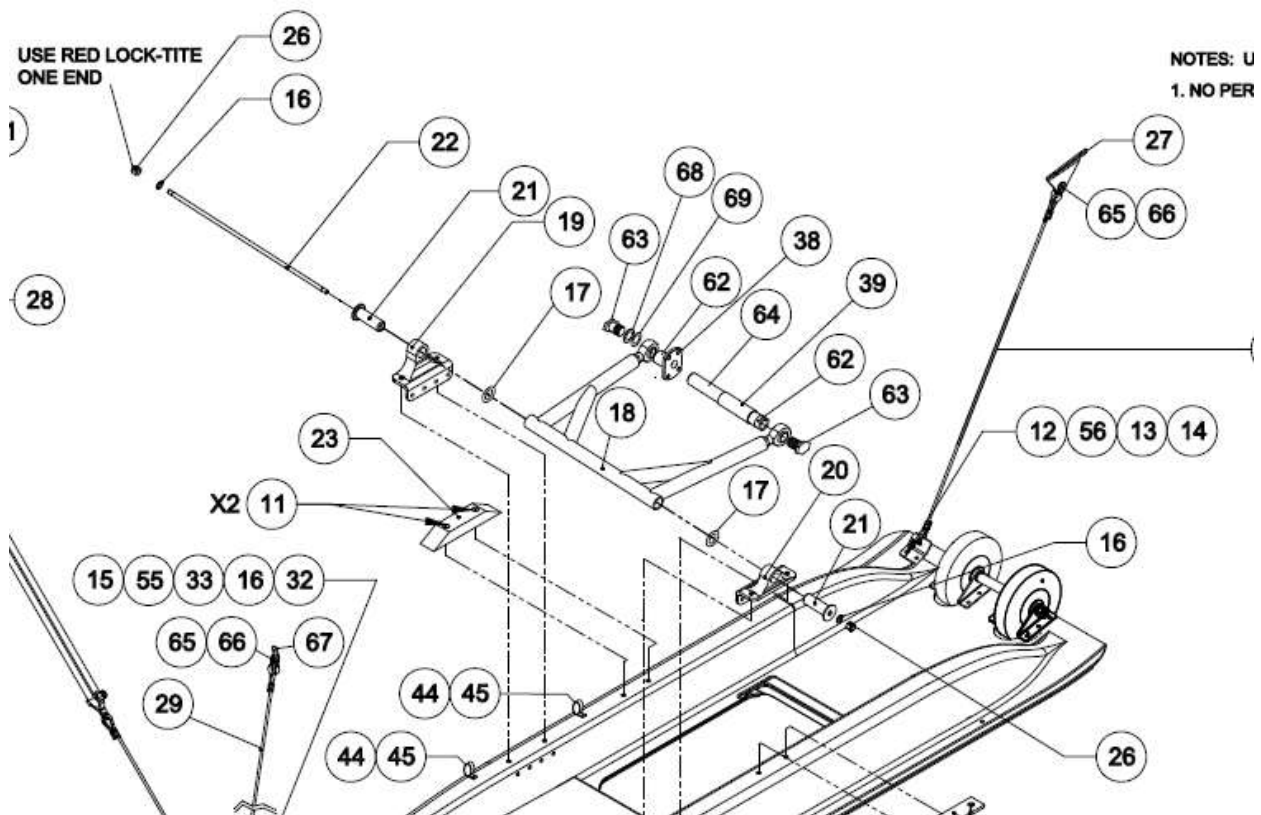

5. The yokes will need to be inspected, using a magnetic particle inspection in accordance with AC43-13-1B, Chapter 5. Area of interest is the welds of the yokes.
6. The welds must be free of powder coat for proper inspection.



7. If no cracks are found, we recommend a 1" wide .100 4130N finger strap be welded on the outboard yoke arms. This will be an intermediate fix for the yoke. Weld strap with the use of AC43-13-1B, Chapter 4. Length of finger should allow a minimum of 2" of weld on the outboard attachment arm on both sides. **Intermediate finger straps repairs will eliminate further inspection requirements.**

8. The **best option** is to replace yokes with current generation yokes. Current generation yokes are of much higher strength and very resistant to high sideward shock loads. These yokes are not heat-treated and have internal build-ups. The lack of heat treatment makes them more ductile. This is the best option to prevent future cracking problems. Airglas will offer yokes at a low cost for 24 months from the date of this Service Bulletin.



TEMPLATE FOR FINGER STRAP
REPAIR. USE 4130N STEEL .100"
THICK

