

D

NOTE: MOUNT BRACKET (#1) SO AFT EDGE IS PARALLEL TO STA. 0.00

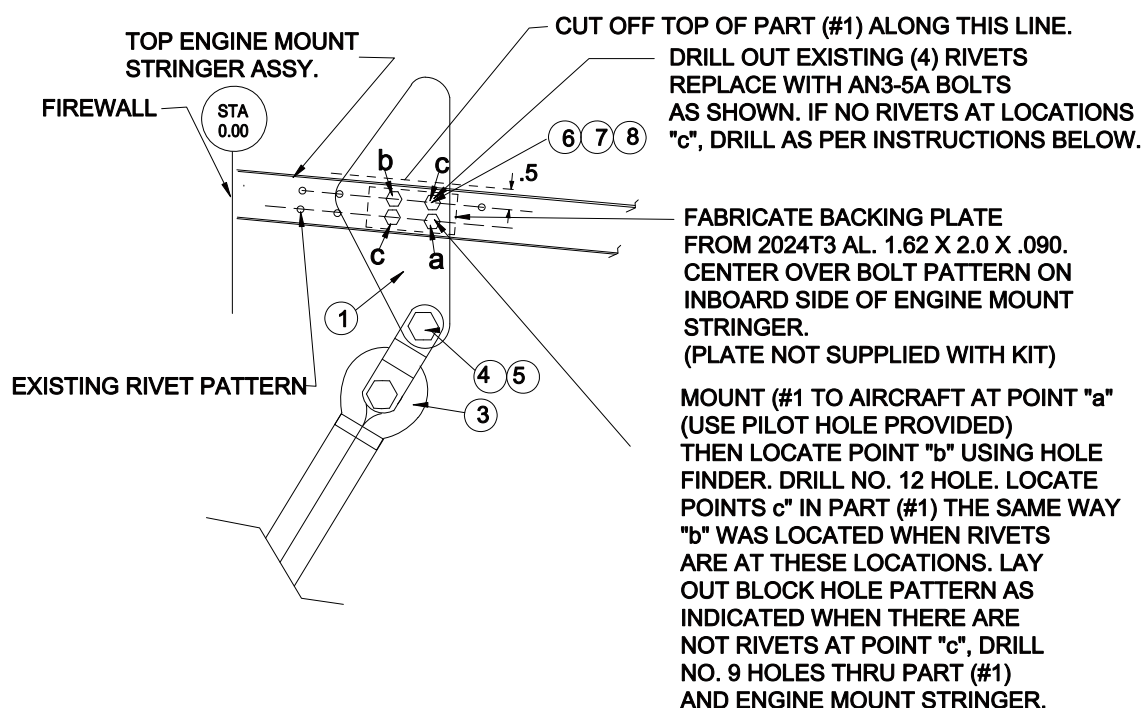

CESSNA 180 THRU 180F AIRCRAFT

3 LOCATIONS TYP.

NOTE: MOUNT BRACKET (#1) SO AFT EDGE IS PARALLEL TO STA. 0.00

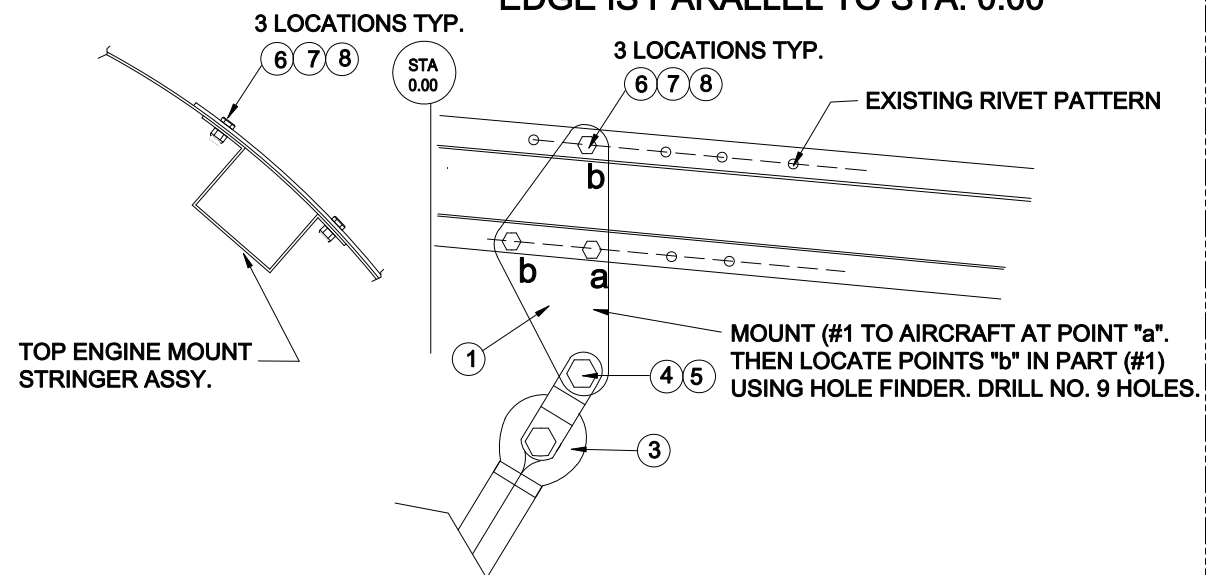

CESSNA 180G THRU 180K AND 185 AIRCRAFT

NO.	QTY	CODE IDENT. NO.	PART NUMBER	DESCRIPTION	STOCK SIZE	MATERIAL	MATERIAL SPEC.	UTS 1000	FINISH	CALC. UNIT	ACT. WT	ZONE
16	2	17564	AN380-3-2	COTTER PIN (REF.)								
15	2	17564	AN395-19	CLEVIS PIN (REF.)								
14	2	17564	LH3600-13	CHECK CABLE ASSY. (REF.)								
13	1	17564	LH3600-18-1	RIGHT HAND DOUBLER (NOT SHOWN)								
12	1	17564	LH3600-17-1	LEFT HAND DOUBLER								
11	2		CR3213-6-4	RIVET								
10	1	17564	LH3600-18	RIGHT HAND RIGGING BRACKET (NOT SHOWN)								
9	1	17564	LH3600-17	LEFT HAND RIGGING BRACKET								
8	14*		AN3-5A	BOLT								*16 REQUIRED ON 180 THRU 180F
7	14*		AN365-1032	NUT								*16 REQUIRED ON 180 THRU 180F
6	14*		AN960-10	WASHER								*16 REQUIRED ON 180 THRU 180F
5	2		AN364-624	NUT								
4	2		AN6-5A	BOLT								
3	2	17564	LH3600-14	BUNGEE CABLE ASSY. (REF.)								
2	1	17564	LW3600-180A-10	RIGHT HAND RIGGING BRACKET (NOT SHOWN)								
1	1	17564	LW3600-180A-9	LEFT HAND RIGGING BRACKET								

LIST OF MATERIALS

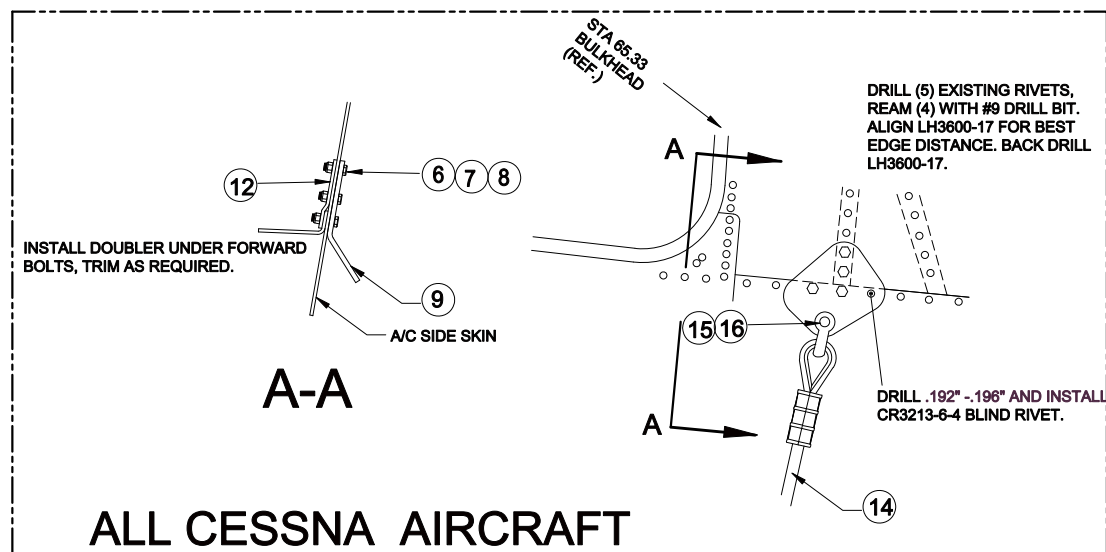

ALL CESSNA AIRCRAFT

NOTES:

- 1. UNLESS OTHERWISE SPECIFIED, NO PERMISSIBLE ALTERNATIVE CONSTRUCTION.
- 2. QUANTITY SHOWN IS FOR EACH SHIP SET.
- 3. LEFT HAND DEPICTED, RIGHT HAND OPPOSITE.

REVISION BLOCK

REV	Description	APP'D BY	DATE

UNLESS OTHERWISE SPECIFIED DIMENSIONS ARE IN INCHES TOLERANCES EXCEPT AS NOTED

DECIMALS .X ± .1 ANGLES .XX ± .050 .XXX ± .015

FRACTIONS ± 1/64

Cessna 180/185

NEXT ASSY. USED ON

APPLICATION

CONTRACT NO.

SPEC. CONTROL NO.

Approved by : JDH

Checked by : JDH

Drawn by : CDB

Date Aug. 20, 2012

THIS DRAWING OR DOCUMENT INCLUDES INFORMATION PROPRIETARY TO AIRGLAS Inc. AND IS SUBMITTED FOR EVALUATION ONLY AND SHALL NOT BE USED TO MANUFACTURE OR REPRODUCE WITHOUT PERMISSION OF AIRGLAS Inc.

Size Code Ident.No. Rev

A 17564 LH3600-180A-9 & LH3600-17 INST.

Scale: DO NOT SCALE

Sheet 1 OF 1

AIRGLAS, INC.
Anchorage, Alaska

**LH4000 RIGGING BRACKET
INSTALLATION CESSNA 180/185**

A

B

C

D